

# Improved fast scanning delay line in optical coherence tomography applications utilizing fiber stretcher

Lianshan Yan,<sup>a</sup> X. Steve Yao,<sup>b</sup> Lynn Lin,<sup>b</sup> and Xiaojun Chen<sup>b</sup>

<sup>a</sup>Southwest Jiaotong University, Center for Information Photonics and Communications, Chengdu, Sichuan, China, 610031

<sup>b</sup>General Photonics Corp., 5228 Edison Ave., Chino, California 91710

E-mail: lsyan@home.swjtu.edu.cn

**Abstract.** We demonstrate an improved fiber-stretcher-based scanning delay line in terms of both the scanning speed and the delay range. Such a module is essential to optical coherence tomography (OCT) applications. An 18-mm delay range at 2-kHz scanning frequency is achieved and verified in a dental OCT setup. Repeatability and reliability of the new design are further evaluated through multiple trials within days. The results confirm its feasibility into practical applications. © 2008 Society of Photo-Optical Instrumentation Engineers.  
[DOI: 10.1117/1.2976796]

Subject terms: delay line; fiber stretching; optical coherence tomography.

Paper 080414LRR received Jun. 2, 2008; revised manuscript received Jul. 7, 2008; accepted for publication Jul. 19, 2008; published online Oct. 6, 2008.

## 1 Introduction

Optical coherence tomography (OCT) has been one of the hot research topics in the last few years and has become one of the promising biomedical solutions as related techniques being improved.<sup>1-8</sup> Compared to conventional methods, OCT is capable of cross-sectional imaging of biological tissues or even organs at micrometer-scale resolution. In general, the OCT technique can be achieved in either time-domain (TD-OCT), utilizing scanning time delay lines, or frequency-domain (FD-OCT), scanning the spectrum of the light source itself. As one of the key components of TD-OCT systems, scanning delay lines should have several desired features, especially the high scanning speed and large generated delay range.

Although various schemes of scanning delay lines have been demonstrated in research labs,<sup>9-11</sup> unfortunately, it is difficult in practice to generate a large delay change while keeping the delay variation speed sufficiently high and without sacrificing the reliability.

In this paper, we demonstrate an improved scanning delay line using fiber-stretching technology. Through special and optimized design of the mechanical body and the stretching mechanism, both the scanning speed and the generated delay range are significantly increased. An 18-mm delay at 2 kHz is achieved with superior reliability

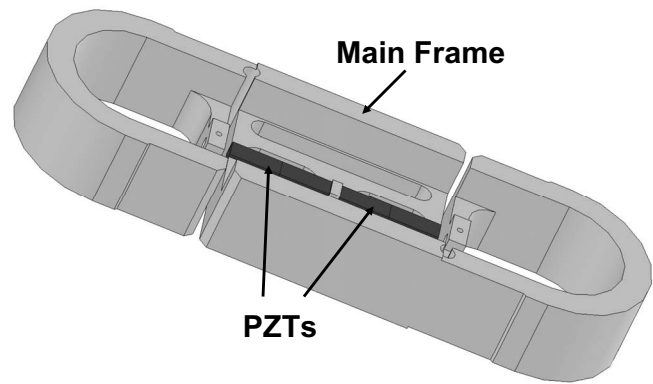

**Fig. 1** Illustration of the improved fiber stretcher design, showing the two PZTs and the main frame.

(for practical purposes). This improved design with large scanning range and high speed is further verified in a dental OCT setup.

## 2 Improved Fiber Stretcher Design

Several problems existed in previous and available fiber-stretcher designs: (i) unsatisfied reliability, especially the repeatability, and (ii) generating limited delay range, typically several millimeters (e.g., 2–3 mm). To solve these problems, we specially design a new fiber stretcher as shown in Fig. 1, with several highlighted features: (i) two piezo-electric actuators (PZTs) are used to provide longitudinal stretch on the mechanical frame (used to hold optical fibers); (ii) the mechanical frame is optimized to match the resonance behavior of the PZTs, hence, capable of providing high-speed stretching; and (iii) special procedures are used to secure the optical fibers winding on the frame, such as fiber gluing, to improve the reliability and repeatability. The intrinsic loss of such a module can be as low as 0.1 dB if the optical connector losses are neglected (~0.5 dB with connectors).

## 3 Results and Discussion

On the basis of this new design, we test the generated delay versus driving frequency using the Mach-Zehnder interferometer configuration (not shown here, as can be found in various fundamental literature). The delay is calculated by

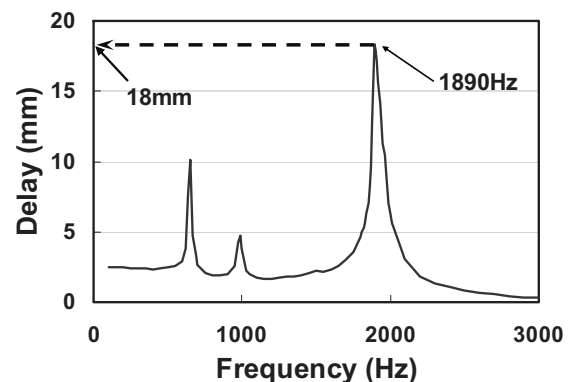

**Fig. 2** Measurement results of generated delay vs driving frequency (the amplitude of the driving signal is 55 V).

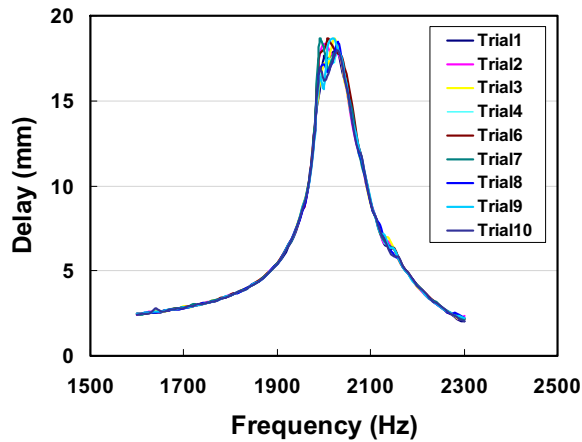
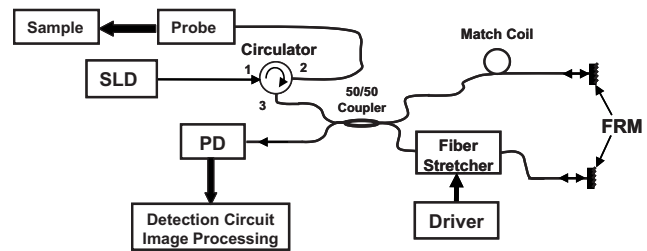

**Fig. 3** Repeatability (reliability) evaluation results with ten independent trails around the resonant frequency  $\sim 2$  kHz.

counting the interference fringes through a frequency counter. Each interference fringe corresponds to a delay variation of a center wavelength  $\lambda_{\text{Source}}$  (1550-nm light source is used). Assuming that the frequencies of the interference signal and the reference signal are  $f_{\text{Interference}}$  and  $f_{\text{Reference}}$ , respectively, the delay range can be calculated as  $(\lambda_{\text{Source}} f_{\text{Interference}}) / (2 f_{\text{Reference}})$ . Figure 2 shows measurement results with a driving voltage of only 55 V. At the resonant frequency of the new fiber stretcher (i.e., 1890 Hz, which though, can also be tuned to slightly above 2 kHz), the generated delay can be as high as 18 mm (corresponding to a scan speed of  $\sim 34$  m/s). There are also some peaks with less generated delay at other frequencies (e.g.,  $\sim 13$  and 19 kHz), where the delay is typically  $< 1$  mm limited by the electronic driving circuits.

Furthermore, we evaluate the reliability (repeatability) of this new module driven at the resonant frequency (i.e.,  $\sim 2$  kHz). The results are shown in Fig. 3. Ten independent trails are taken in several days under the same measurement environment (e.g., the driving voltage and frequency), and the almost overlapping traces in Fig. 3 indicate a promising repeatability in terms of delay versus frequency: the delay variation around the resonant frequency is very small and the window of the resonant frequency is not a narrow one ( $\sim 100$  Hz). The superior repeatability can guarantee reliable OCT scanning results, while the 100-Hz frequency window can release the requirements for the accuracy and stability of the driving frequency. Both advantages are desired features for practical applications.

As such a fast scanning delay line is ideal for OCT applications (e.g., dental or eye diagnosis), where a large delay scanned at high frequencies is generally required, we build a simple dental OCT setup (1-D only) to verify the improved design (Fig. 4). Again, the fiber stretcher is driven at  $\sim 2$  kHz. A tooth sample is scanned in one direction using a probe, and the interference output is detected through a fast photodetector [InGaAs PIN type]. The detection circuit includes a transimpedance amplifier and a demodulation circuit. A data acquisition (DAQ) card is used to capture instantaneous voltages (converted from intensities of optical signals) to construct images. The typical result is shown in Fig. 5. Two different positions [Fig. 5(a) and 5(b)] of a tooth sample are measured and processed as



**Fig. 4** Evaluation setup for the 1-D dental OCT application. SLD: Super luminescent diode; PD: photodetector; FRM: Faraday rotation mirror.

the probe scanning the sample along the horizontal direction. We can clearly see the profile of the tooth, even at the sharp edge. Note that the picture is symmetric because of the scanning itself, which is not eliminated in our software.

Here although we optimize the design to have such characteristics, it is still possible to further increase the delay range, as well as the resonant frequency, through more rigorous, and also more time- and cost-consuming engineering designs.

#### 4 Conclusion

We improved the current fiber-stretcher design to significantly increase both the scanning speed and the delay range and further verified the module in a dental OCT setup. Such

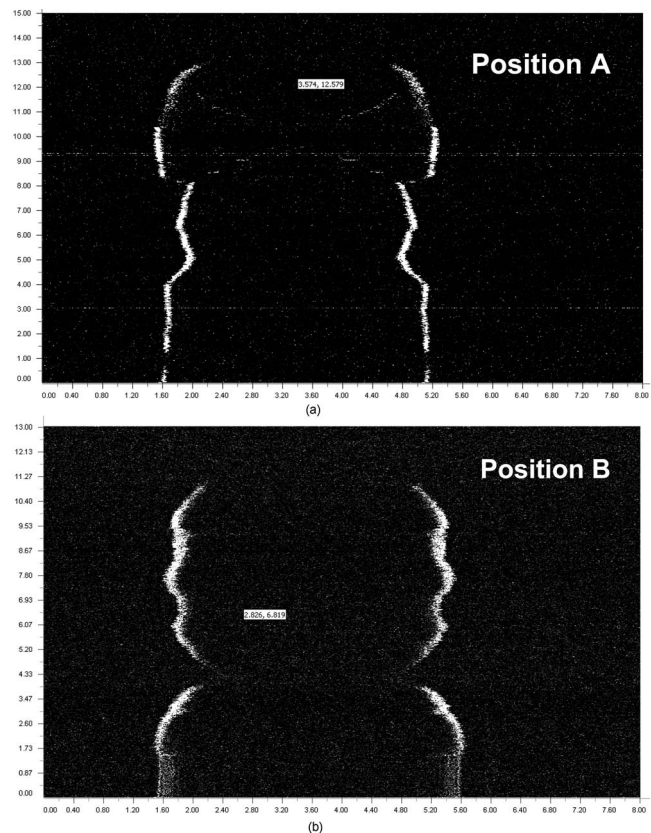

**Fig. 5** (a, b) Photos taken at two different positions as the probe crossing the tooth sample in the horizontal direction.

a module can be used as an essential part for TD-OCT applications, as well as other possible ones (e.g., microwave photonics networks<sup>12</sup>).

### Acknowledgments

The authors thank Karen Li and Peter Betts at General Photonics Corp. for help with the design and measurements.

### References

1. D. Huang, E. A. Swanson, C. P. Lin, J. S. Schuman, W. G. Stinson, W. Chang, M. Hee, R. T. Flotte, K. Gregory, C. A. Puliafito, and J. G. Fujimoto, "Optical coherence tomography," *Science* **254**, 1178–1181 (1991).
2. Z. Yaqoob, J. Fingler, X. Heng, and C. H. Yang, "Homodyne *en face* optical coherence tomography," *Opt. Lett.* **31**(12), 1815–1817 (2006).
3. J. E. Roth, J. A. Kozak, S. Yazdanfar, A. M. Rollins, and J. A. Izatt, "Simplified method for polarization-sensitive optical coherence tomography," *Opt. Lett.* **26**(14), 1069–1071 (2001).
4. W. Y. Oh, B. E. Bouma, N. Iftimia, R. Yelin, and G. J. Tearney, "Spectrally-modulated full-field optical coherence microscopy for ultrahigh-resolution endoscopic imaging," *Opt. Express* **14**(19), 8675–8684 (2006).
5. J. M. Schmitt, "Optical coherence tomography (OCT): A review," *IEEE J. Sel. Top. Quantum Electron.* **5**(4), 1205–1215 (1999).
6. S. Guo, J. Zhang, L. Wang, J. Nelson, and Z. Chen, "Depth-resolved birefringence and differential optical axis orientation measurements with fiber-based polarization-sensitive optical coherence tomography," *Opt. Lett.* **29**, 2025–2027 (2004).
7. M. Choma, M. Sarunic, C. Yang, and J. Izatt, "Sensitivity advantage of swept source and Fourier domain optical coherence tomography," *Opt. Express* **11**(8), 2183–2189 (2003).
8. R. Leitgeb, C. K. Hitzenberger, and A. F. Fercher, "Performance of Fourier domain vs. time domain optical coherence tomography," *Opt. Express* **11**, 889–894 (2003).
9. C. C. Rosa, J. Rogers, and A. G. Podoleanu, "Fast scanning transmissive delay line for optical coherence tomography," *Opt. Lett.* **30**, 3263–3265 (2005).
10. G. J. Tearney, B. E. Bouma, and J. G. Fujimoto, "High-speed phase- and group-delay scanning with a grating-based phase control delay line," *Opt. Lett.* **22**, 1811–1813 (1997).
11. X. Liu, M. J. Gobb, and X. Li, "Rapid scanning all-reflective optical delay line for real-time optical coherence tomography," *Opt. Lett.* **29**, 80–82 (2004).
12. ALMA project (<http://www.alma.nrao.edu/science/sciencegoals.html>).