

All-optic scheme for automatic polarization division demultiplexing

X. Steve Yao^{1,2}, L.-S. Yan², B. Zhang^{2,3}, A. E. Willner³, and Junfeng Jiang¹

1. Polarization Research Center and Key Laboratory of Opto-electronics Information and Technical Science (Ministry of Education), Tianjin University, Tianjin 300072, China

2. General Photonics Corp. Chino, CA, 91710, USA

3. Department of Electrical Engineering-Systems, University of Southern California, Los Angeles, CA, 90089, USA
xyao@generalphotonics.com; lsyan@generalphotonics.com

Abstract: We describe a cost effective scheme to automatically separate two polarization channels in a polarization division multiplexing (PDM) system, without having to modify the existing transmitter or receiver electronics or software. We experimentally validate the concept by achieving an extinction ratio of more than 28-dB between two demultiplexed channels. Finally, we successfully demonstrate the PDM scheme in a 1.12-Tb/s (14×2×40-Gb/s) system over 62-km of transmission fiber.

©2007 Optical Society of America

OCIS codes: (060.2330) Fiber optics communications; (060.2360) Fiber optics links and subsystems

References and Links

1. S. Bhandare, D. Sandel, B. Milivojevic, A. Hidayat, A. A. Fauzi, H. Zhang, S. K. Ibrahim, F. Wust, and R. Noe, "5.94-Tb/s 1.49-b/s/Hz (40x2x2x40 Gb/s) RZ-DQPSK polarization-division multiplex C-band transmission over 324 km," *IEEE Photon. Technol. Lett.* **17**, 914-916 (2005).
2. L. Leng, S. Stulz, B. Zhu, L.E. Nelson, B. Edvold, L. Gruner-Nielsen, S. Radic, J. Centanni, and A. Gnauck, "1.6-Tb/s (160x10.7 Gb/s) transmission over 4000 km of nonzero dispersion fiber at 25-GHz channel spacing," *IEEE Photon. Technol. Lett.* **15**, 1153-1155 (2003).
3. Y. Frignac, G. Charlet, W. Idler, R. Dischler, P. Tran, S. Lanne, S. Borne, C. Martinelli, G. Velth, A. Jourdan, J. Hamaide, and S. Bigo,, "Transmission of 256 wavelength-division and polarization-division-multiplexed channels at 42.7Gb/s (10.2 Tb/s capacity) over 3x100km of TeraLight fiber," in Proc. OFC'02 Postdeadline, Anaheim, CA, paper FC5 (2002).
4. D. Borne, S. L. Jansen, E. Gottwald, P. M. Krummrich, G.-D. Khoe, and H. Waardt, "1.6-b/s/Hz spectrally efficient 40 x 85.6-Gb/s transmission over 1,700 km of SSMF using POLMUX-RZ-DQPSK," in Proc. OFC'06 Postdeadline, Anaheim, CA, paper PDP34 (2006).
5. A. R. Chraplyvy, A. H. Gnauck, R. W. Tkach, J. L. Zyskind, J. W. Sulhoff, A. J. Lucero, Y. Sun, R. M. Jopson, F. Forghieri, R. M. Derosier, C. Wolf, and A. R. McCormick, "1-Tb/s transmission experiment," *IEEE Photon. Technol. Lett.* **8**, 1264-1266 (1996).
6. P. M. Hill, R. Olshansky, and W. K. Burns, "Optical polarization division multiplexing at 4 Gb/s," *IEEE Photon. Technol. Lett.* **4**, 500-502(1992).
7. S. G. Evangelides, L. F. Mollenauer, J. P. Gordon, and N. S. Bergano, "Polarization multiplexing with solitons," *J. Lightwave Technol.* **10**, 28-35 (1992).
8. K. Iwatsuki, K. Suzuki, S. Nishi, and M. Saruwatari, "80 Gb/s Optical soliton transmission over 80 km with time/polarization division multiplexing," *IEEE Photon. Technol. Lett.* **5**, 245-247(1993).
9. M. I. Hayee, M. C. Cardakli, A. B. Sahin, and A. E. Willner, "Doubling of bandwidth utilization using two orthogonal polarizations and power unbalancing in a polarization-division-multiplexing scheme," *IEEE Photon. Technol. Lett.* **13**, 881-883 (2001).
10. Y. Han, and G. Li, "Experimental demonstration of direct-detection quaternary differential polarization-phase-shift keying with electrical multilevel decision," *Electron. Lett.* **42**, 109-111 (2006).
11. R. Noe, S. Hinz, D. Sandel, and F. Wust, "Crosstalk detection schemes for polarization division multiplex transmission," *J. Lightwave Technol.* **19**, 1469-1475 (2001).

12. G. Charlet, H. Mardoyan, P. Tran, A. Klekamp, M. Astruc, M. Lefranc,ois and S. Bigo, "Upgrade of 10 Gbit/s ultra-long-haul system to 40 Gbit/s with APol RZ-DPSK modulation format," *Electron. Lett.* **41**, 1240-1241 (2005).
13. X. Steve Yao, US patent application #60/575,127 (2005).
14. L.E. Nelson, and H. Kogelnik, "Coherent crosstalk impairments in polarization multiplexed transmission due to polarization mode dispersion," *Opt. Express* **7**, 350-361 (2000).
15. L.E. Nelson, T. N. Nielsen, and H. Kogelnik, "Observation of PMD-Induced coherent crosstalk in polarization-multiplexed transmission," *IEEE Photon. Technol. Lett.* **13**, 738-740 (2001).
16. D. Borne, N. E. Hecker-Denschlag, G. D. Khoe, and H. Waardt, "PMD-induced transmission penalties in polarization-multiplexed transmission," *J. Lightwave Technol.* **23**, 4004-4015 (2005).

1. Introduction

Increasing the transmission capacity or spectral efficiency of an existing fiber system without having to change any part of transmission hardware or software is an attractive proposition for carriers or system operators, because it can significantly reduce the system "down" time and minimize the equipment and installation cost for system upgrade. One method for doubling the system capacity or spectral efficiency is polarization-division-multiplexing (PDM), in which two independently modulated data channels with the same wavelength, but orthogonal polarization states are simultaneously transmitted in a single fiber [1-12]. At the receiver end, the two polarization channels are separated and detected independently. Ideally, the operator only needs to add a transceiver (identical to the existing ones in the system) and an associated polarization multiplexer/demultiplexer at each end of the fiber link, while leaving the rest of the system, including fibers, amplifiers, repeaters, wavelength MUX/DMUX, optical add/drop multiplexers (OADM), switching optics, and even the network management software, unchanged, as shown in Fig. 1, or with minimal modification. Other methods of increasing system spectral efficiency, such as reducing the channel wavelength spacing or increasing transceiver bit rate, require significant system re-design, and are therefore not suitable for the upgrade of existing systems, although they may be feasible for the implementation of new systems.

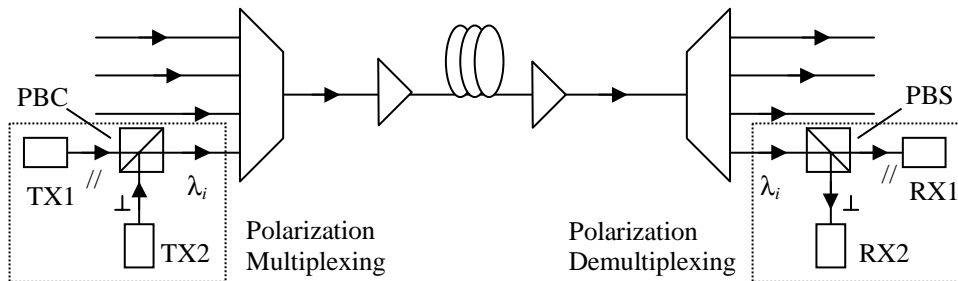

Fig. 1. Illustration of a polarization division multiplexing (PDM) system

Significant challenges remain for the practical deployment of PDM systems, including finding an effective polarization demultiplexing solution and overcoming polarization cross-talk between the two polarization channels induced by polarization-mode-dispersion (PMD) and polarization-dependent-loss (PDL). In this paper, we will concentrate on a cost-effective polarization demultiplexing solution, assuming that the PMD and PDL of the system is sufficiently low for polarization multiplexed transmission.

Polarization multiplexing is straightforward, requiring only a polarization beam combiner (PBC) to combine two channels with orthogonal polarizations, as shown in Fig. 1. However, separating the two channels with acceptable cross-talk at the receiving end is not trivial, because the polarization states of the two channels are no longer linear, and change rapidly

with time. It is possible to monitor the cross-talk of the two channels in real time and then use the monitored information to dynamically control the states of polarization (SOP) of the two polarization channels in order to separate them with a polarization beam splitter. So far, no good method has been found to monitor the cross-talk optically; therefore, one must rely on the detected electronic signal in the receiver to monitor cross-talk. Previously proposed schemes include (i) monitoring of clock tone or pilot tones [5-8] (ii) multi-level electronic detection [9-10], and (iii) cross-correlation detection of the two demultiplexed channels [11]. Each of these schemes has one or more of the following drawbacks: (i) it requires high-speed electronics, thereby making it bit-rate dependent; and more importantly (ii) it requires modification or even significant re-design of existing transceivers, making it more difficult to upgrade existing systems.

In this paper, we propose and demonstrate a simple all optical demultiplexing scheme to automatically separate the two polarization channels in PDM systems, as shown in Fig. 2. Our approach requires only two low-speed photodetectors, a polarization controller, and the associated low-speed control circuits, making it bit-rate and modulation-format independent. Specifically, we launch slightly different amounts of optical power into the two polarization channels. Using the detected power difference between the two channels as the feedback signal to control the dynamic polarization controller, the two polarization channels at the same wavelength can be readily separated and then detected by two identical receivers. This scheme requires no modification of the existing transmitter, receiver, or transmission link. Even high-speed electronics are not required. All that a system operator needs to do to double the transmission capacity of the link is to add a transmitter card and a polarization beam combiner at the transmitting end, before the wavelength multiplexer, and a receiver card and the polarization channel separator described in this paper after the wavelength demultiplexer.

In the following sections, we first describe theoretically the new polarization demultiplexing scheme based on channel power imbalance. We then show our experimental validation of the scheme by separating two polarization multiplexed channels with a power imbalance of just above 0.5 dB. Finally, we show the results of a successful system demonstration of the scheme by doubling the transmission capacity of a DWDM system containing 14 WDM channels at 40-Gb/s per channel over 62-km LS (LEAF-Submarine by Corning Inc.) fiber transmission.

2. Description of the Concept

The conceptual diagram of the automated detection scheme for a PDM system is shown in Fig. 2 [13]: Optical data streams with orthogonal SOPs (TX1 and TX2) are generated from the same or different light sources at the same wavelength, and are then multiplexed through a polarization beam combiner (PBC). During signal transmission over a fiber link, the two linear SOPs evolve into elliptical SOPs but still maintain their relative orthogonality, assuming that the fiber link has no PDL and PMD. A dynamic polarization controller (DPC) followed by a polarization beam splitter (PBS) is used to demultiplex the two data streams of orthogonal SOPs. Choosing the transmission axes of the PBS as reference coordinates x and y for convenience, the corresponding Mueller matrix of the PBS can be expressed as:

$$M_x = \frac{1}{2} \begin{bmatrix} 1 & 1 & 0 & 0 \\ 1 & 1 & 0 & 0 \\ 0 & 0 & 0 & 0 \\ 0 & 0 & 0 & 0 \end{bmatrix} \quad (1)$$

$$M_y = \frac{1}{2} \begin{bmatrix} 1 & -1 & 0 & 0 \\ -1 & 1 & 0 & 0 \\ 0 & 0 & 0 & 0 \\ 0 & 0 & 0 & 0 \end{bmatrix} \quad (2)$$

Optical data stream i with an arbitrary SOP \bar{S}_i can be expressed in Stokes space as:

$$\bar{S}_i = \begin{bmatrix} S_{i0} \\ S_{i1} \\ S_{i2} \\ S_{i3} \end{bmatrix} = \begin{bmatrix} P_i \\ P_i \cos 2\varepsilon_i \cos 2\theta_i \\ P_i \cos 2\varepsilon_i \sin 2\theta_i \\ P_i \sin 2\varepsilon_i \end{bmatrix} \quad (3)$$

where P_i is the optical power, ε_i is the ellipticity angle, and θ_i is the orientation angle of the i th optical data stream. After passing through the PBS, the Stokes vectors along the x and y directions are $M_x \bar{S}_i$ and $M_y \bar{S}_i$, respectively, where the first row of each Stokes vector represents the optical power along the corresponding direction. In particular,

$$P_{ix} = \frac{1}{2} P_i (1 + \cos 2\varepsilon_i \cos 2\theta_i) \quad (4)$$

$$P_{iy} = \frac{1}{2} P_i (1 - \cos 2\varepsilon_i \cos 2\theta_i) \quad (5)$$

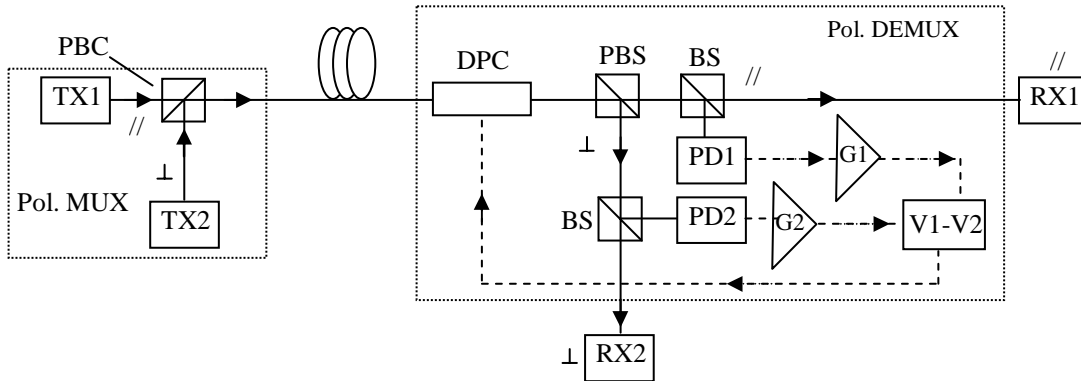

Fig. 2. Conceptual diagram of proposed Polarization DEMUX using automated feedback control (solid-line: optical path; dotted-line: electronic control). PBC: polarization combiner, PBS: polarization splitter, BS: beamsplitter, DPC: dynamic polarization controller, G1 & G2: electrical amplifiers, PD1 & PD2: photodetectors.

Since the two data streams are incoherent with each other (they are either generated using two independent laser sources or are rendered incoherent by other means), the optical powers emerging along the x and y axes of the PBS are

$$P_x = P_{1x} + P_{2x} = \frac{1}{2} P_1 (1 + \cos 2\varepsilon_1 \cos 2\theta_1) + \frac{1}{2} P_2 (1 + \cos 2\varepsilon_2 \cos 2\theta_2) \quad (6)$$

$$P_y = P_{1y} + P_{2y} = \frac{1}{2} P_1 (1 - \cos 2\varepsilon_1 \cos 2\theta_1) + \frac{1}{2} P_2 (1 - \cos 2\varepsilon_2 \cos 2\theta_2) \quad (7)$$

For the two optical data streams with orthogonal SOPs \bar{S}_1 and \bar{S}_2 , the following relationships hold:

$$\varepsilon_2 = -\varepsilon_1 \quad (8)$$

$$\begin{cases} \theta_2 = \theta_1 + \frac{1}{2}\pi, & 0 \leq \theta_1 \leq \frac{1}{2}\pi \\ \theta_2 = \theta_1 - \frac{1}{2}\pi, & \frac{1}{2}\pi < \theta_1 \leq \pi \end{cases} \quad (9)$$

Substituting Eq.(4) and Eq.(5) into Eq.(6) and (7) yields

$$P_x = \frac{1}{2}(P_1 + P_2) + \frac{1}{2}(P_1 - P_2)\cos 2\varepsilon_1 \cos 2\theta_1 \quad (10)$$

$$P_y = \frac{1}{2}(P_1 + P_2) - \frac{1}{2}(P_1 - P_2)\cos 2\varepsilon_1 \cos 2\theta_1 \quad (11)$$

To automatically and effectively separate the two orthogonal data channels, we monitor the relative optical power levels of the two channels by coupling a small amount of the signal power into two low-speed photodetectors (PD1 and PD2). Through low-noise electronic circuits (G_1 and G_2), the power difference between the two polarization states ($P_x - P_y$) is translated into the voltage difference ($V_1 - V_2$), expressed as:

$$V_1 - V_2 = \alpha_1 P_x - \alpha_2 P_y = \frac{1}{2}(\alpha_1 - \alpha_2)(P_1 + P_2) + \frac{1}{2}(\alpha_1 + \alpha_2)(P_1 - P_2)\cos 2\varepsilon_1 \cos 2\theta_1 \quad (12)$$

where α_1 and α_2 are the response coefficients of the two photodetectors and their corresponding amplification circuits. Through electronic gain balancing or software calibration, they can be adjusted to be equal ($\alpha_1 = \alpha_2 = \alpha$) and therefore the voltage difference of Eq. (12) becomes

$$\Delta V = V_1 - V_2 = \alpha(P_1 - P_2)\cos 2\varepsilon_1 \cos 2\theta_1 \quad (13)$$

As long as there is a power difference between the two channels ($P_1 - P_2 \neq 0$), the voltage difference between the two power monitors depends on the orientation angle θ and ellipticity angle ε , which can be changed by the dynamic polarization controller. Therefore, by maximizing the calibrated voltage difference ΔV , we can effectively minimize the crosstalk and readily separate the two orthogonal channels by forcing either a positive maximum [$(\theta = 0^\circ, \varepsilon = 0^\circ)$ or $(\theta = \pm 90^\circ, \varepsilon = \pm 90^\circ)$] or a negative maximum [$(\theta = \pm 90^\circ, \varepsilon = 0^\circ)$ or $(\theta = 0^\circ, \varepsilon = \pm 90^\circ)$]. The positive maximum corresponds to a Stokes vector of (1,0,0) while the negative maximum corresponds to a Stokes vector of (-1,0,0).

3. Experimental verification

We implemented this simple yet novel demultiplexing scheme with a digital signal processor (DSP) based circuit, a fiber squeezer polarization controller, a polarization beamsplitter, and two monitoring photodetectors, as shown in Fig. 2. The two monitoring photodetectors obtain the voltage difference defined in Eq. (13) and feed it back to the DSP circuit. Our DSP firmware then automatically instructs the polarization controller to control the state of polarization to maximize the voltage difference (either a positive maximum or a negative maximum). The two polarization channels are considered to be separated when the maximum voltage difference is reached and maintained.

First we evaluate the concept using two static wavelength channels (~ 1 -nm separation) launched at two orthogonal polarization states with different power levels. The reason for the use of different wavelengths is to distinguish the two polarization channels with an optical spectrum analyzer (OSA). This does not affect the result because the scheme is wavelength independent. After the polarization demultiplexer, we measure the extinction ratio (ER) using an optical spectrum analyzer, as shown in Fig. 3. A stable ER of >28 -dB can be achieved when the power difference between the two channels is higher than 0.5 dB. For higher power differences (e.g. >1 -dB), a stable ER >35 dB is possible. The remaining crosstalk is mainly due to electronic noise and the limits of the feedback accuracy, with the upper limit determined by the ER of the PBS inside the polarization demultiplexer (>40 -dB). Because the

scheme is wavelength independent, the experiment indicates that two polarization channels of the same wavelengths can also be effectively separated.

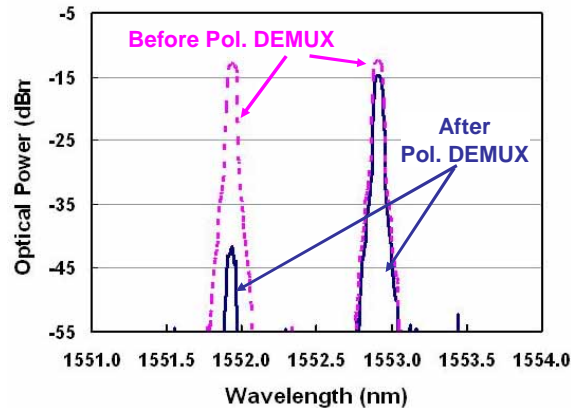

Fig. 3. Concept proof using two static wavelength channels with different power levels: here the power difference is ~ 0.5 -dB (before Pol. DEMUX), and an ER of ~ 28 dB is achieved with the proposed polarization demultiplexing scheme (after Pol. DEMUX). >35 -dB ER is possible as the power difference increases.

We next use this polarization demultiplexing scheme in a single-channel 10-Gb/s back-to-back (i.e. no transmission fiber) transmission setup. The data signal is RZ modulated from a short pulse laser source with a wavelength of ~ 1550 -nm, separated into two arms with orthogonal polarization states, and then combined into one transmission port (fiber) using a PBC. Fig. 4(a) shows the power penalty of the demultiplexed signals as a function of the power difference between the two orthogonal channels (PDM_V and PDM_H). As can be seen from the figure, the power penalties of both polarization channels are less than 0.5 dB when the power difference between the channels is larger than 1 dB. Even when the power difference is 0.5 dB, the additional power penalties are only 0.25 and 0.75 dB for two orthogonal channels. As an example, the comparisons of bit-error-rate (BER) curves are shown in Fig. 4(b), with typical eye diagrams also inserted. The slight deviation of BER curves below 10^{-9} is mainly due to the response of the 10-GHz receiver to the short-pulse laser source and to possible measurement instabilities.

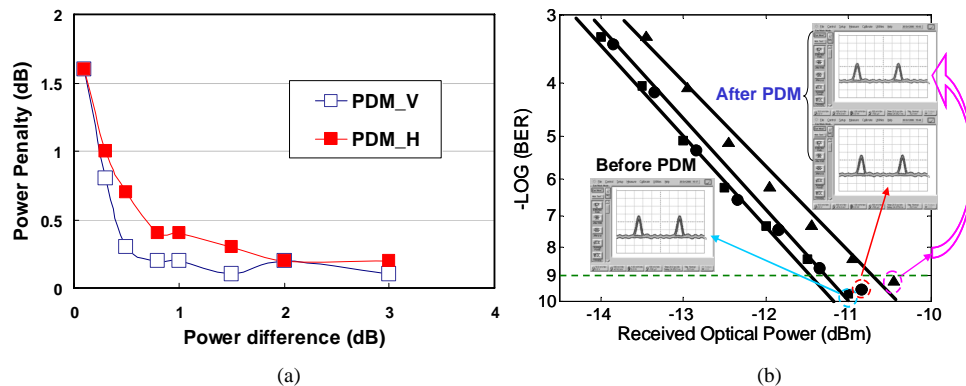

Fig. 4. Evaluation of proposed polarization demultiplexing scheme in a single-channel 10-Gb/s RZ back-to-back transmission setup. (a) Power penalties of both polarization channels (PDM_H and PDM_V) as a function of power difference between them. (b) Bit-error-rate (BER) curves as the power difference between two orthogonal channels is set to 0.5 dB (i.e. the power of PDM_V is 0.5-dB higher than that of PDM_H); the corresponding power penalties for the two orthogonal channels compared to the case without PDM are ~ 0.25 dB and 0.75 dB, respectively. Square: back-to-back without PDM. Circle: PDM-V. Triangle: PDM-H.

4. 1.12-Tb/s PDM transmission

To further evaluate the effectiveness of the proposed automated polarization demultiplexing scheme, we demonstrate a 1.12-Tb/s ($14 \times 2 \times 40$ -Gb/s) PDM transmission system over 62-km LS fiber with the experimental setup shown in Fig. 5(a). For this demonstration, we used 14 WDM channels with a spacing of 0.8-nm (from 1546.8 nm to 1557.2 nm) operating at 40 Gb/s. In a practical system, each wavelength channel should be comprised of two DFB lasers, two modulators, and a polarization beam combiner to multiplex the two polarization channels into a single fiber before the combined signal enters the wavelength division multiplexer (WDM) [5], as shown in Fig. 1. Alternatively, for demonstration purposes, all 14 multiplexed channels can be separated into two orthogonal polarizations by a PBS and then modulated by two independent modulators, before finally being combined by a PBC. However, due to equipment limitations, we further simplified the demonstration without losing generality as follows: all fourteen channels are modulated at 40-Gb/s PRBS ($2^{11}-1$) using a single modulator (the spectra of all fourteen channels are shown in Fig. 5b) because we only have one 40-Gb/s modulator in the lab. Each channel is separated into two orthogonal polarization states (PDM_V and PDM_H with powers P_1 and P_2 , respectively) and multiplexed through the PBC with ~ 35 dB extinction ratio. One of the arms incorporates a 1-km SMF to make sure that the two polarization channels are incoherent with each other; this is sufficient because the coherence lengths of transmission lasers are less than 1 km. The power difference is fixed at 1.0 dB (P_1 is higher than P_2). The input optical power into the 62-km LS fiber is set to be 4 dBm. An optical filter with a bandwidth ~ 0.35 nm is used to select one of the channels. Either of the two orthogonal data streams is chosen for bit-error detection at the receiver end by activating the proposed Pol. DEMUX via the feedback control of the dynamic polarization controller. Although the Pol. DEMUX module has two outputs, we only need to measure the performance at one port by switching the control parameter (maximizing V_1-V_2 or V_2-V_1). The total 62-km LS fiber link has ~ 0.6 -ps PMD and ~ 0.15 dB PDL on average.

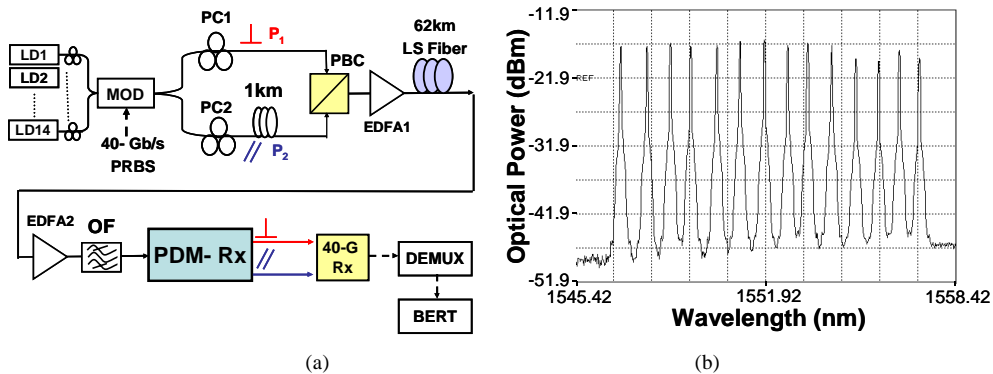

Fig. 5. Experimental demonstration of 14-channel 1.12-Tb/s WDM-PDM transmission: (a) experimental setup; (b) optical spectrum of all 14 channels.

The performances of all 14 channels after the 62-km LS fiber are compared in Fig. 6(a), for both polarization channels (PDM_V and PDM_H). The power penalties are compared to the best channel receiver sensitivity measured at 10^{-9} BER for the back-to-back PDM transmission (~ 0.8 dB additional penalty compared to the back-to-back transmission without PDM). Since the optical power of PDM_V is 1.0-dB higher than PDM_H, with the contributions of both optical-signal-to-noise-ratio (OSNR) and possible chromatic dispersion, the performance of PDM_V is better than PDM_H by about 1 dB for all of the channels: the power penalties for PDM_V ranges from 1.8 to 3.1 dB, while the power penalties of PDM_H range from 2.8 dB to 4.2 dB. As a reference, the penalty for a regular WDM transmission

over the same 62-km link with the same setup is ~ 1.0 -dB (40-Gb/s data rate). The relatively high power penalties in the PDM transmission system may be due to the following reasons: (i) intrinsic crosstalk between the two polarization states; (ii) imperfection of the polarization tracking after transmission links; and (iii) link sensitivity (PMD, PDL, etc.) of the PDM scheme itself. In addition, typical BER curves for one of the fourteen channels are shown in Fig. 6(b).

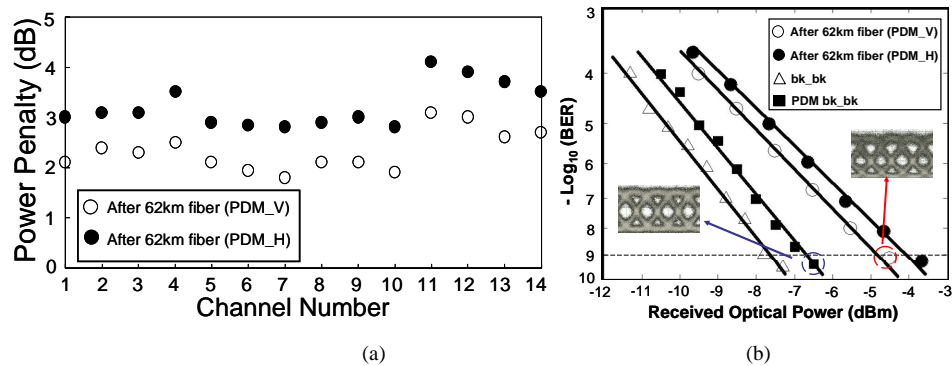

Fig. 6. Transmission results (a) Power penalties of both polarization channels (PDM_V and PDM_H) for all 14 wavelength channels compared to the back-to-back PDM system sensitivity measured at 10^{-9} BER. (b) Typical BER curves of one wavelength channel with eye diagrams inserted: bk_bk (back-to-back case without PDM transmitter); PDM bk_bk (back-to-back case with PDM transmitter).

5. Discussion

In addition to experimental demonstrations, several key issues remain: (i) the sensitivity to power difference: As described in the concept, due to the limitation of the electronics, as the power difference decreases (<0.5 -dB), the effectiveness of the feedback control decreases (i.e. lower ER); (ii) the effect of PDL and PMD: PDL along the link may degrade the power difference set at the transmitters and invalidate the demultiplexing. Under the worst-case scenario, PDL may totally wipe out the power difference. On the other hand, the effect of the PDL also includes the OSNR improvement or degradation along the transmission link. The tradeoff between power difference and PDL should be considered for system optimization. Since this scheme does not target PMD immunization, the effects of PMD are expected to be similar to those of other approaches that have been studied in the literature [14-16]. Related issues (e.g. PMD impairments and mitigation) and optimization are under further investigation.

6. Summary

We have described a new polarization demultiplexing scheme for separating two polarization multiplexed channels based on channel power imbalance. We validated the scheme with a power imbalance of just above 0.5 dB in a system containing a single wavelength channel. Finally, we successfully demonstrated the scheme in a DWDM system containing 14 WDM channels of 40-Gb/s per channel over 62-km LS fiber transmission.

Acknowledgments

We thank Zhangfeng Wang, A. Belisle, Lynn Lin of General Photonics Corporation for helping on the electronic and mechanical design, and Teichen Wang and Shoufeng Lan of Tianjin University for some experimental efforts.