

Making Light Work Lighter

General Photonics

C O R P O R A T I O N

POS – 002

Fiber-Optic Polarization Tracker

Operation Manual

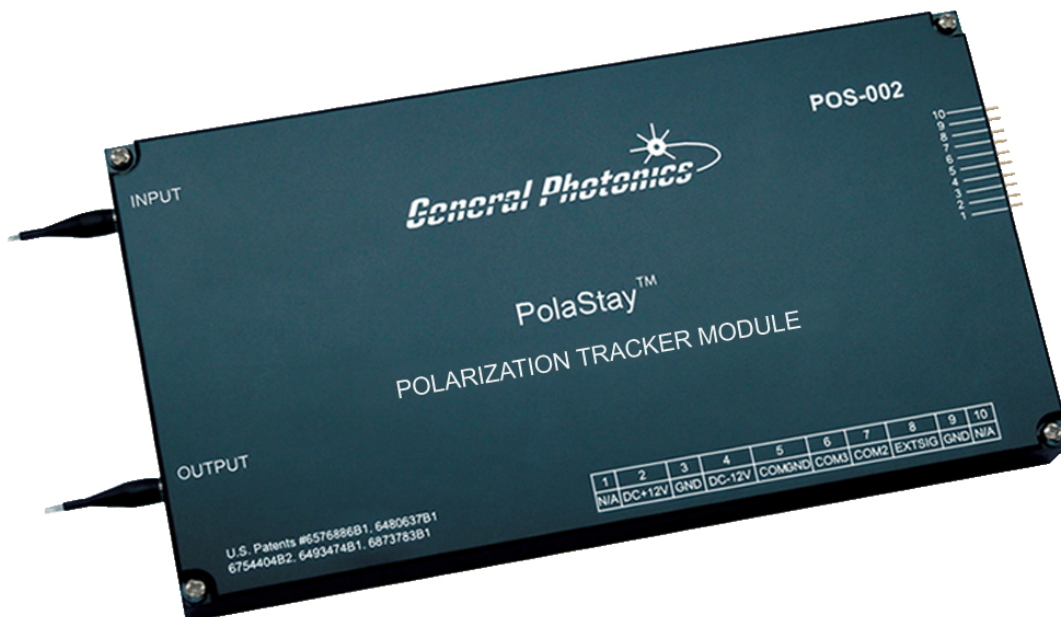

September 27, 2013

General Photonics Corp.
5228 Edison Ave.
Chino, CA 91710 USA

Ph: (909) 590-5473
Fax: (909) 902-5536
www.generalphotonics.com

WARRANTY

All of General Photonics' products have been inspected and found to comply with our stringent quality assurance standards before shipping. If any damage occurs during shipment, please contact the carrier and inform us or our distributors as soon as possible.

Please do not, under any circumstances, attempt user repair of any General Photonics product. To avoid further damage, any repair of defective products must be performed by well-trained engineers.

General Photonics warrants that this product will be free from defects in materials or workmanship for a period of one year from the date of original shipment (listed on the certificate of quality or packing list enclosed with the original shipment). A product found to be defective during the warranty period will be repaired or replaced, at no charge, at General Photonics' option.

If a problem is found, please contact General Photonics for assistance. If necessary, return the defective product, freight prepaid, clearly labeled with the RMA number, with as complete a description of the problem as possible. The repaired or replacement product will be returned, freight prepaid, as soon as possible.

The above warranty specifically excludes products that have been repaired or modified by non-manufacturer-authorized personnel, as well as damage caused by misuse, abuse, improper storage or handling, or acts of nature.

This warranty is in lieu of all other warranties, expressed or implied. General Photonics will not be liable for any indirect or consequential damages or losses resulting from the use of its products.

SAFETY CONSIDERATIONS

The following safety precautions must be observed during operation, service and repair of this product. Failure to comply with these precautions or with specific warnings elsewhere in this manual violates safety standards of design, manufacture, and intended use of the product. General Photonics Corp. assumes no liability for customers' failure to comply with these requirements.

- **Before operation, the user should inspect the product and review the manual carefully.**
- Make sure that the product is in a secured work environment (in terms of temperature, humidity, electrical power, hazard due to fire or shock, etc.) for proper operation.
- Standard laser safety procedures should be followed during operation.

Table of Contents:

Section 1. Specifications:	5
Section 2. Overview:	6
Section 3. Feature Descriptions:	8
3.1 Optical Features:	8
3.2 Electrical Features:	9
Section 4. Operation Instructions:	10
4.1 Unpacking	10
4.2 Getting Started	11
4.3 Testing and Characterization:	12
4.4 Remote control and programming:	13
4.4.1 RS-232 Connection	13
4.4.2 Remote operation and commands	14
4.4.3 RS-232 troubleshooting	22
4.4.4 LabView control program	22
Section 5. Application Examples	26
5.1 PMD compensation	26
5.2 Polarization Demultiplexing	27
5.3 Coherence detection	29
5.4 Polarization tracking for sensor system	29
Section 6. Technical Support	30

Section 1. Specifications:

Physical Features:

Package Dimensions	7.25" (L) × 3.86" (W) × 0.75" (H)
Fiber Input/Output Connectors ¹	FC/PC or FC/APC
Weight	2 lbs

System Specifications:

Operating wavelength ²	1310 or 1550±50 nm standard
SOP Recovery Time	< 3 ms (0.9 ms typical)
SOP accuracy ³	< 0.1 dB
Repeatability	< 0.1 dB
SOP Rotation tracking speed (reset free)	47π/s
Insertion loss	Internal feedback: 0.8 dB typ., 1.2 dB max. External feedback: <0.1 dB
Return loss	> 50 dB
Isolation in orthogonal polarization	>20 dB
Optical input power	-20 dBm to 20 dBm for internal feedback version
Optical power damage threshold	300 mW
Operation temperature	0 °C to 70 °C
Storage temperature	-20 °C to 70 °C
Power Supply	DC +12V / 0.5A -12V / 0.15A
External feedback voltage	0.5 to 4.6V DC (ext. feedback version only)
Communications interface ⁴	RS-232

Notes: Specifications listed above are for the standard configuration; specs may be different for instruments with different wavelength or input power ranges.

1. Per user specification when product is ordered.
2. Other wavelengths and control algorithms may be available upon request.
3. The output power fluctuation caused by SOP fluctuation after passing through a polarizer.
4. Requires special cable (provided).

Section 2. Overview:

The POS-002 is a compact fiber-optic polarization tracker module designed and manufactured by General Photonics Corporation. It integrates General Photonics' award-winning PolaRite™ III polarization controller, an optical polarization detection circuit, and a microprocessor based electronic control circuit into an automatic, remote-controllable system. The POS-002 is packaged in a small, watertight enclosure for easy integration into user systems, as shown in Figure 1. Its fast response, low insertion loss, and reset-free operation make it well-suited for use in coherent communications, fiber-optic sensors, fiber-optic interferometers, and other applications that require an actively optimized state of polarization (SOP). General Photonics' proprietary polarization control algorithm allows the POS-002 to compensate for sudden polarization discontinuities as well as continuous slow polarization drift in one or more directions.

The standard POS-002 polarization tracker with SM output fiber covers the 1260-1650 nm fiber transmission window. A short wavelength custom version can also be made to cover a wavelength range from 970 nm to 1260 nm. Versions with PM output typically have a wavelength range of center wavelength ± 50 nm.

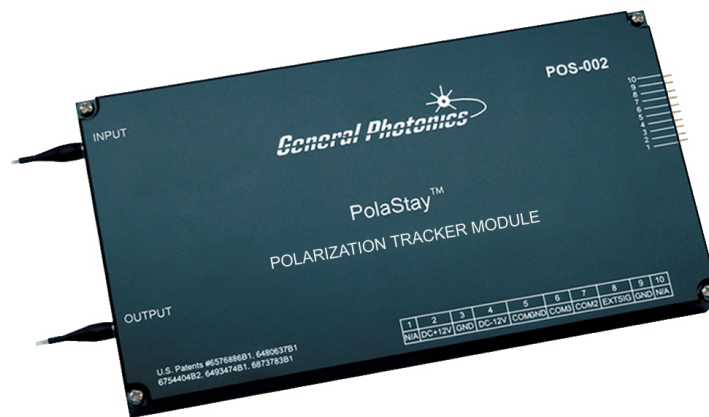

Figure 1 POS-002 polarization tracker module for fiber-optic systems

The operation of the POS-002 is based on a feedback system, as shown in Figure 2. It is internally controlled by a microprocessor.

For versions with internal optical feedback control, the POS-002's internal polarization monitoring system is based on General Photonics' PolaDetect™ polarimeter or a simplified version. The polarization monitoring system intercepts only a small fraction of input light, so that the total insertion loss of the system is small (<1 dB) for totally polarized input light.

For an arbitrary input polarization state, the polarization monitor measures the output polarization state and then sends a feedback signal to the polarization controller. The optimization process is repeated until the desired output SOP is achieved.

The POS-002 can also be factory configured to use external feedback control. In this case, the feedback signal is a DC or quasi-DC voltage generated by the user. This feedback signal can correspond to any parameter that is to be optimized by the polarization controller, such as digital clock level, optical extinction ratio, clear eye pattern area, receiver power level, local oscillator level, interferometer fringe contrast, SOP, etc. In this configuration, the polarization monitor unit (composed of the components in the dashed line box shown in Figure 2) is not installed. In this case, the optical path of the entire module is a continuous section of optical fiber. Therefore, the optical insertion loss from the polarization controller can be disregarded.

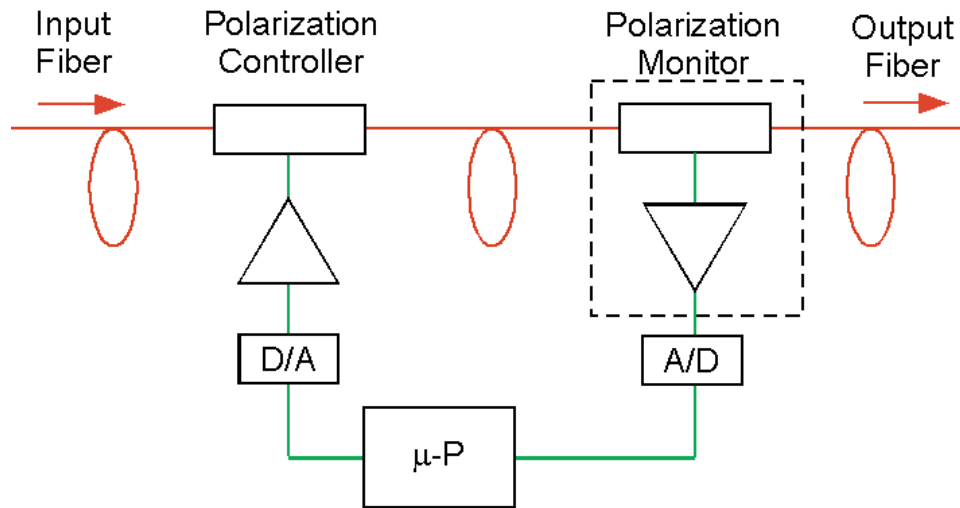

**Figure 2 POS-002 polarization tracker block diagram.
Standard model with internal optical feedback**

Section 3. Feature Descriptions:

3.1 Optical Features:

The POS-002 polarization tracker has two optical fiber connectors: an input connector to receive the input light beam and an output connector to couple the polarization optimized light beam downstream. The input/output fiber connector type can be specified by the user when the module is ordered.

All fiber connectors should be cleaned using industry standard cleaning methods before making connections to the POS-002.

There are two output fiber options for POS-002 modules: PM output fiber and single mode (SM) output fiber, as shown in Figure 3 (a and b). The two output options have different features.

The internal feedback POS-002 has PM fiber output. In this configuration, a linear polarizer is inserted in the optical path. Therefore, the output SOP is fixed, and is aligned to the slow axis (default) or fast axis (if the user specifies it) of a PM fiber. With the POS-002 disabled, the output power can fluctuate if the input SOP changes. Once the tracker is enabled, the output power will be stabilized along with the SOP. The PM fiber output version of the POS-002 is extremely useful when the fiber-optic component/system following it has PM fiber at the input. Examples include electro-optic modulators or PM coupler/combiners.

The external feedback POS-002 has SM fiber output. In this configuration, there is no polarizer in the output optical path. Therefore, the output optical power is a constant. Once the tracker is enabled, the output SOP will be actively adjusted to optimize the parameter of interest. If the feedback signal is set up for SOP stabilization, this means that the SOP will be confined to a tiny circle on the Poincaré sphere centered on the target SOP. This configuration is useful when the fiber optic system following the POS-002 has SM fiber at the input.

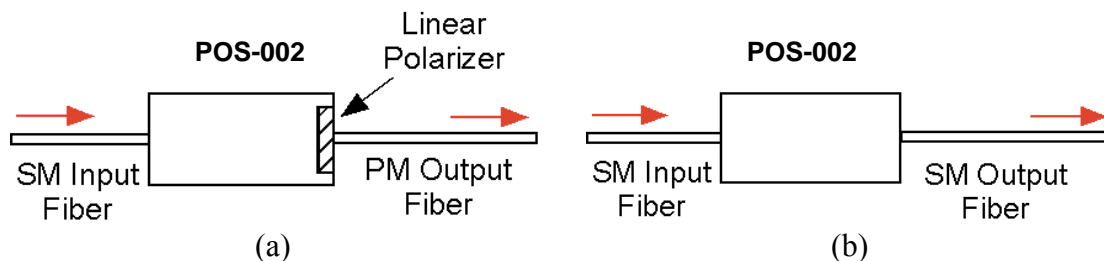

Figure 3 Two output configurations of the POS-002 polarization tracker: (a) fixed SOP with stabilization in optical power, and (b) fixed output power with stabilization in SOP

For internal feedback units, the maximum input optical power is approximately +20dBm (100 mW). For optical power higher than 20 dBm (100 mW), please contact General Photonics, or specify when ordering.

3.2 Electrical Features:

The POS-002 uses a microprocessor based measurement system. The polarization tracking function is continuously monitored and fully automatic. There are no user serviceable parts in the system, and no calibration is required.

The POS-002 requires + 12V/0.5A and -12V/0.15A DC power supplies. Due to the presence of internal high voltages, the following safety precautions must be exercised during operation.

- The ground pin on the power cable must be connected to earth ground of the power supply.
- Never touch the boards inside the package without proper insulation and grounding.
- The POS-002 is not user serviceable and can be serviced only by factory-authorized personnel.

The power and communication connections and pin definitions for the POS-002 are listed below. Pin definitions and labels are also shown on the POS-002 overlay (see cover picture or Figure 1). An RS-232 interface (using the special cable provided) can be used for remote control operation. A 2-part cable is provided for power/communication connections to the POS-002. The first section connects to the POS-002 module, and includes the functions shown in the pin definition in Table 1: power, RS-232, and external feedback signal input (for external feedback version POS-002). The second section connects to the 3-pin connector on the first section, and has a DB9 connector on the other side for RS-232 interface with a computer. Remote operation can be achieved by using any program that supports the RS-232 communication protocol. A simple LabView™ (National Instruments, www.ni.com) interface is provided for RS-232 control. RS-232 control commands are listed in Section 4.4.1, and Section 4.4.4 contains a description of the control program.

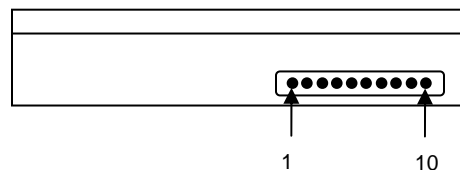

Figure 4 POS-002 electrical/communication connector

Table 1 Electrical/communication connector pinout

Pin	Definition
1	Not Used
2	+12VDC
3	GND
4	-12VDC
5	COMGND
6	RXD
7	TXD
8	EXTSIG (external feedback)
9	GND
10	Not Used

Section 4. Operation Instructions:

Electrical and optical connections are required during initial setup of the POS-002. The relevant safety precautions should be followed when making these connections.

Warnings:

- **Never look into the light source fiber connector when light source is turned on. THE OUTPUT LIGHT FROM A HIGH POWER LASER IS HARMFUL TO HUMAN EYES. Please follow industry standard procedures when operating a high power laser source.**
- **Although the POS-002 is packaged in a watertight enclosure, it still requires external electrical connections. It is therefore advisable to avoid water condensation or liquid spills in its vicinity at all times.**
- **Check optical power level of the input optical beam. Make sure the optical power level at the input connector is below 20 dBm (100 mW).**

4.1 Unpacking

Inspect POS-002 to check for any physical damage due to shipping and transportation. Contact carrier if any damage is found. Check the packing list for any missing parts or accessories.

Avoid excess vibration environments when using the POS-002 system. External high frequency vibration may affect the accuracy of SOP stabilization.

Avoid pulling or small-radius bending of the Input/Output fibers. Damage to the pigtailed can affect performance, loss, and the watertightness of the enclosure.

4.2 Getting Started

The POS-002 is enabled by default, with control settings at their default values, when it is powered on. The following steps describe the setup procedure:

1. The POS-002 has mounting holes at each corner of the enclosure. Use M3 screws to anchor the module in place.

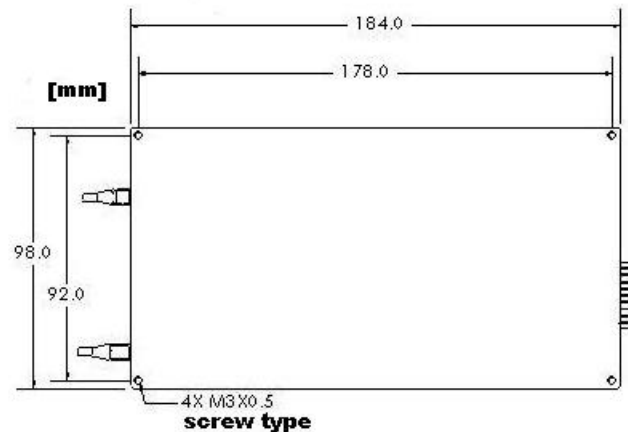

Figure 5 Mechanical drawing of POS-002 with mounting hole/screw information

2. Connect power source to power pins (PIN2: +12VDC; PIN3: GND; PIN4: -12VDC). If the POS-002 is being installed as part of a larger system, make sure that its ground is common with the ground for the rest of the system.
3. If the input optical power level is not known, measure it with an optical power meter. Make sure that it is below 20 dBm (100 mW) for internal feedback units.
4. After verifying input optical power level, connect the input fiber to the input connector of the POS-002. It is important to clean the fiber connector using industry standard procedures. For a high power laser source, turn off optical power source before connector cleaning.
5. If using external electrical feedback, connect the external feedback signal to the POS-002. (PIN 8: DC error signal, PIN 9: GND).

Guidelines for electrical error signal:

Please note that there is no buffer between the input signal and the A/D converter. To avoid damage to the A/D converter, the error signal should be within the voltage limits listed below.

Feedback Signal Range:

Minimum Voltage Level	0.5 Volts
Maximum Voltage Level	4.5 Volts

Hardware limits:

Conversion time per A/D sample	1.75 μ S (max)
Acquisition Time	0.25 μ S (min)
Maximum Sampling Rate	500 kHz

6. Turn on the DC power supplies. The POS-002 is enabled by default and will begin operation on power-up.
7. After the input fiber is connected and the optical power is turned on, the POS-002 will automatically stabilize the input SOP to a linearly polarized output SOP (internal optical feedback option) or optimize the SOP to either maximize or minimize the error signal (external electrical feedback option). Note: The standard version uses a maximum search algorithm. Minimum search may be available by special request.
8. When SOP stabilization is not needed, such as in a system performance comparison using stabilized and unstabilized input SOPs, the POS-002 can be put into standby (disabled) mode via an RS-232 command (see section 4.4 for details).
9. See section 4.4 for a description of the basic operation cycle and instructions on customizing the setup.

4.3 Testing and Characterization:

The POS-002 can be serviced only by manufacturer-authorized personnel. There are no user serviceable components in this system.

The performance of the POS-002 can be tested with standard polarization measurement instruments or a laboratory setup. The output SOP from the POS-002 can be monitored by a commercial polarization analyzer. For laboratory testing, the user can insert a manual or motorized polarization controller before the input fiber connector, and connect the output fiber to an optical power meter or photodetector. If the POS-002 being tested has the SM output fiber option, a polarizer should be inserted between the output fiber connector and optical power meter. Once the POS-002 is activated, the optical power to the power meter or photodetector will be stabilized, independent of any adjustment of the input polarization controller.

4.4 Remote control and programming:

The POS-002's active tracking can be enabled/disabled, and its operation parameters changed, via remote control. While tracking is disabled, the POS-002 remains in the setting at which it was disabled.

4.4.1 RS-232 Connection

The RS-232 serial interface port allows the user to remote control the POS-002 by sending ASCII commands. The LabView test program provided with the POS-002 shows a programming example.

The POS-002's RS-232 communication pins are located next to its power pins (see Figure 4 and Table 1).

Communication pins on POS-002:

PIN5: GND

PIN6: RXD

PIN7: TXD

Connect the communication pins to the RS-232 port of a computer or other control signal source (see Figure 6 for correspondence between the POS-002 communication pins and the DB9 connector on the connection cable). The POS-002 comes with two connection cables. One has a 10-pin connector on one side to connect to the POS-002. On the other side of that cable are labeled wires for the power and external signal connections, and a 3-pin connector to connect to the RS-232 connection cable. The RS-232 connection cable has a matching 3-pin connector on one side to connect to the first cable, and a DB9 connector on the other side to connect to the RS-232 port of a computer. The pin correspondence for the DB9 connector is shown below, where the numbers in parentheses are the corresponding pin numbers on the POS-002.

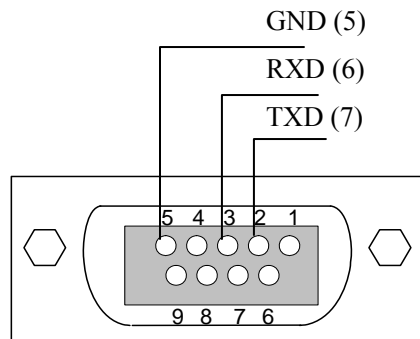

Figure 6 RS-232 connector pin assignment for POS-002.

4.4.2 Remote operation and commands

General Photonics provides a test program for remote control of the POS-002. See section 4.4.4 for installation and operation instructions for the program.

The following steps and commands are recommended for remote operation of the POS-002 using the RS-232 communication port.

1. Connect POS-002 to PC using provided cables.
2. Make sure that the RS-232 port settings on the control computer are as follows:
 - a. Baud rate: 9600 bps
 - b. Framing: asynchronous
 - c. Data bits:8
 - d. Parity bit: None
 - e. Stop bit: 1
 - f. Flow control: None
3. Power on the POS-002 by supplying DC \pm 12V.
4. Make sure that the COM port number setting for the communications program used to send the commands matches the COM port connected to the POS-002.
5. Referring to Table 2 below, send a command string (e.g. “*IDN?”) to the POS-002 through the RS-232 port. There are many programming languages that support serial communications, including Visual Basic, LabView and C.

Table 2 RS-232 Command List:

Query Commands		
Command	Description	Response
*IDN?	Query the Product Number.	*IDN GP-POS-002V2.0-E#
*VER?	Query the Firmware Version.	*VER POS002-V21-020513A# (version dependent)
*MOD?	Query operation status.	*MOD ENA# POS enabled *MOD DIS# POS disabled
*SER?	Query serial number	*1047000004xx#
Control Commands		
*ENA#	Enable polarization tracker.	*E00#
*DIS#	Disable polarization tracker.	*E00#
Setup Commands		
*FUN?	Query current tuning mode.	“Variable” or “Fixed”
*VAR#	Set tuning mode to “variable step size”.	*E00#
*FIX#	Set tuning mode to “fixed step size”.	*E00#

*STS xx#	Set step size. Corresponding angle change = $xx \cdot 0.22^\circ$ on Poincaré Sphere. Range: 1 ~ 75. Default value: 8	“Step Size = xx”
*STS?	Query current step size setting.	“Step Size = xx”
*AVG xx#	Set AD average number Corresponding increase in control loop cycle time = $(xx-1) \cdot 2\mu s$. Range: 1 ~ 20. Default value: 4	“AD AVG = xx”
*AVG?	Request current AD average number	“AD AVG = xx”
*THH xx#	Set response threshold level (sensitivity to noise and polarization change). For 0~5V feedback signal, noise threshold = $xx \cdot 1.22mV$. Range: 0 ~ 150. Default value: 0	“Threshold = xx”
*THH?	Query current threshold level.	“Threshold = xx”
*DLY xxx#	Set additional delay per step. Intrinsic step time is $26\mu s$. The DLY command adds a delay offset to this to slow down the effective step time. Delay offset = $0.5 \cdot xxx \mu s$. Range: 0 ~ 59999. Default value: 5	“*Delay = xxx”
*DLY?	Query current delay offset.	“*Delay = xxx”

Table 3 Command Response Codes:

E00	No error (Correct command received)
E01	Undefined Command
E02	Missing start character
E03	Missing end character
E04	Missing parameter
E05	Invalid syntax found in command string
E06	Invalid mode command.
E07	String of characters too long(>buffer limit)
E08	Light power too high
E09	Light power too low
E10	parameter outside allowed range

RS-232 command notes:

1. Only one command is allowed in each command string.
2. The POS-002 will respond to a command with either the requested data, formatted as described in Table 2, or with one of the response codes listed in Table 3. While the POS-002 is processing a command and sending back a response ASCII code, any additional commands sent by the computer will be ignored.

Basic Operation and Control Parameter Definitions:

A POS-002 using the maximum search algorithm tunes the output state of polarization (SOP) to maximize a feedback signal. This can be an internal reference (POS-002-I) or a 0-5V analog electrical feedback signal provided by the user (POS-002-E). Each time it runs through its control cycle, the POS-002 checks the feedback signal and, if necessary, makes a polarization adjustment.

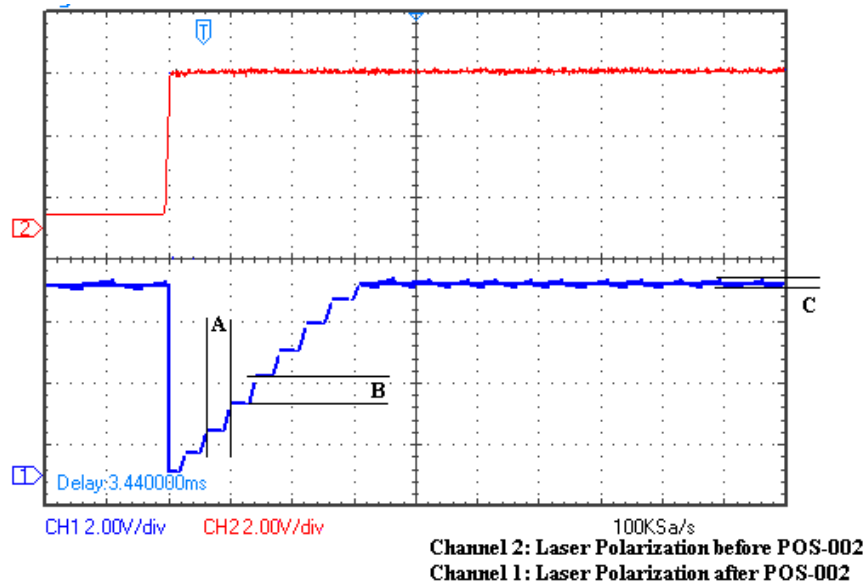

Figure 7 POS-002 response to discontinuous change in input polarization state (using default control settings and fixed step size mode)

Figure 7 shows the response of the POS-002 to a single discontinuous change in the input polarization state, using the default control parameter settings. The red line is the input polarization, and the blue line is the POS-002 output. The POS-002 compensates for the input polarization change via a series of small polarization steps.

The labeled quantities on the graph are as follows:

- A: Step time: With settings delay = 0, AD Avg. = 1, each step takes 26 μ s.
- B: Step size: At step size = 8, the angle change per step $\approx 1.76^\circ$ on the Poincaré sphere.
- C: Output signal fluctuation: The active SOP searching causes a baseline level of fluctuation around the target SOP.

The control parameters allow the user to optimize the POS-002 control cycle for the requirements of particular applications. Their effects on the quantities described above will be explained in the following sections.

Note: The POS-002 does not store user-selected settings in its permanent memory. After it is powered off, all control parameters will revert to the default settings.

Polarization Tuning Modes

The POS-002 has two polarization tuning modes: variable and fixed step size. The default mode is variable step size. In this mode, the POS-002 dynamically adjusts the step size that it uses within a range of one to six times the step size set by the most recent *STS xx# command. This allows it to react quickly, using a larger step size, when the SOP is far from the target, and then to use a smaller step size closer to the target to smooth out the response.

In fixed step size mode, the POS-002 uses a constant step size, set using the *STS xx# command, for its polarization adjustments.

The *VAR# and *FIX# commands are used to select variable and fixed step size modes, respectively, and the *FUN? command is used to query the current operation mode.

Control Parameters

The setup commands in the command list are used to set or to request the current values of the control parameters for the feedback control loop.

- **Command: *STS xx#**

The step size defines the control voltage increment applied to the polarization controller per control loop cycle in response to a change in feedback signal level. The POS-002 uses a 0V~150V voltage output to control the polarization controller. This control voltage range is converted to $2^{12} = 4096$ digital steps for the purposes of the control algorithm. 1 digital step = $150\text{V}/4096 = 0.0366\text{V} \approx 0.2^\circ$ on the Poincaré sphere. The *STS xx# command therefore sets the voltage output step size to $xx * 0.0366\text{V}$, and the corresponding polarization step on the Poincaré sphere to approximately $xx * 0.2^\circ$.

The default setting is 8, corresponding to a control voltage step of $8 * 0.0366\text{V}$, which results in a maximum polarization change of about 1.76° on the Poincaré sphere. In fixed step size mode, this step size remains constant at the selected value. In variable step size mode, the set value is used as the base step size when the POS-002 begins polarization adjustment.

The following figures illustrate the effects of step size selection. For easier illustration, the measurements were taken with the POS-002 in fixed step size mode.

Figure 10 shows the POS-002 output polarization vs. time in response to a discontinuous change in input polarization, using the default step size setting.

If a smaller step size is chosen, the resulting output polarization will be smoother, but more steps are needed to compensate for a given amount of input polarization change. Figure 8 shows the POS-002 output polarization vs. time in response to a discontinuous change in input polarization, using a step size setting smaller than the default value.

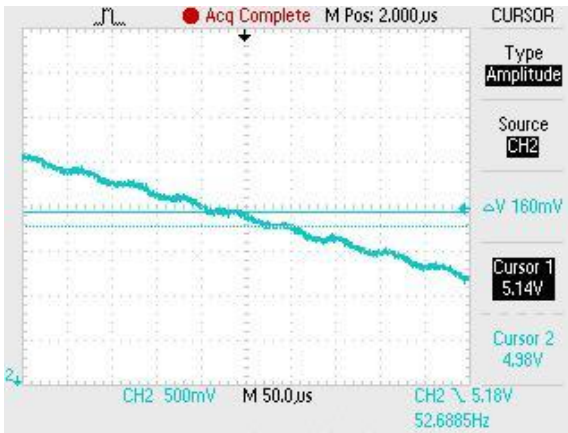

Figure 8 POS-002 output, reduced step size

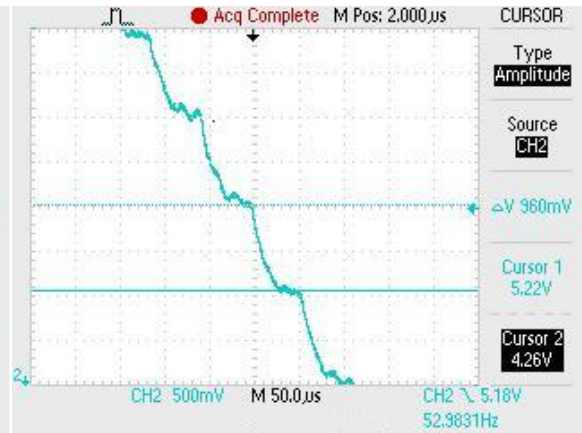

Figure 9 POS-002 output, step size = default

Choosing a larger step size will reduce the response time, but can also increase noise. Figure 10 shows the response of the POS-002 to the same discontinuous change in the input polarization state as in Figure 7, but with a low threshold setting and a step size setting larger than the default value. Compared to Figure 7, the total recovery time is smaller, but the output polarization fluctuation (labeled C in Figure 7) increases.

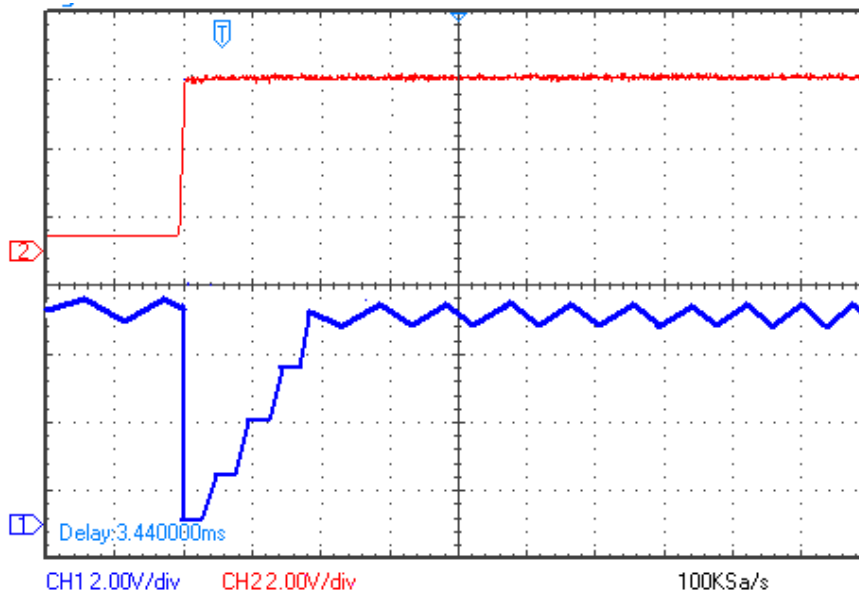

Figure 10 POS-002 response to discontinuous change in input polarization state (step size larger than default setting)

If the optical signal is relatively stable, with changes occurring on a long time scale, a smaller step size can yield better results. A larger step size is better for dealing with a quickly changing input polarization.

- **Command: *DLY xxx#**

The intrinsic time required per control cycle is about 26 μ s. However, for some applications, a slower cycle time may be needed. For example, the optical signal sampling used to generate the feedback signal may be done at a location far away from the POS-002, or the electronics used to generate the feedback signal may need time to respond to polarization changes made by the controller. The DLY command adds a delay offset to the period between a polarization controller step and the next read of the feedback signal, increasing the effective cycle time to $26 + 0.5 * xxx + 2 * (yy - 1) \mu$ s, where xxx is the delay setting and yy is the AD average setting.

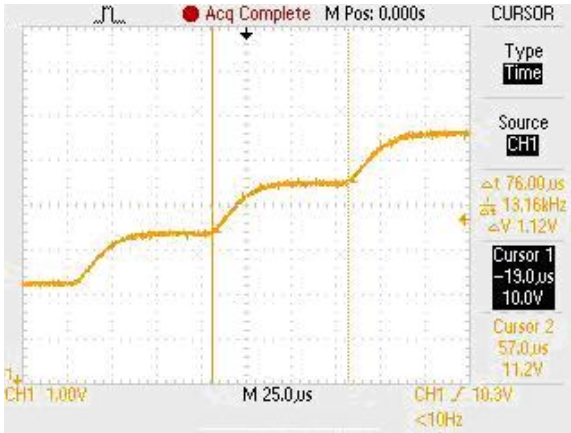

Figure 11 POS-002 output, delay = 100

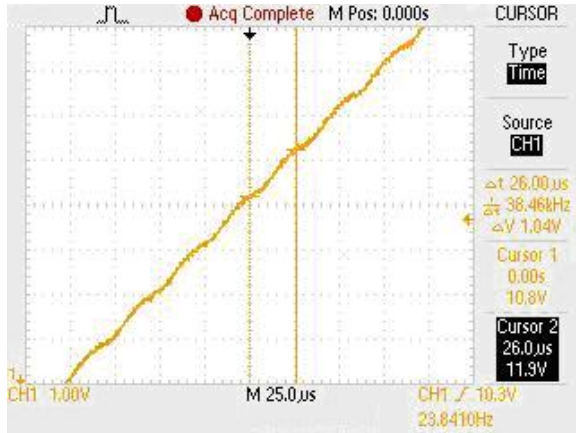

Figure 12 POS-002 output, delay = 0

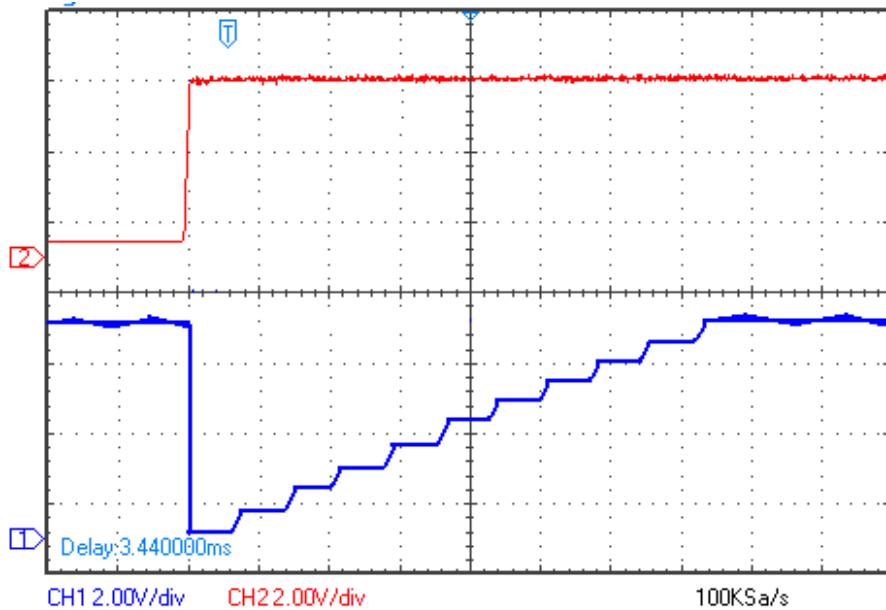

Figure 13 POS-002 response to discontinuous change in input polarization state (delay = 50)

Figure 13 shows the response of the POS-002, using a delay setting of 50, to the same discontinuous change in the input polarization state used in Figure 7. It can be seen that the time per step, and thus the cumulative response time, is longer. Figure 11 and 12 provide a closeup comparison of the response time with different delay settings.

- **Command: *AVG xx#**

During each control loop cycle, the POS-002 performs one adjustment (step) to the polarization control voltage, checks the AD feedback once and compares it with a reference value to decide its action for the next cycle. For an external feedback model, the quality of the feedback signal is the limiting factor in device performance. Any noise in the feedback signal will be read as input polarization change and will therefore result in output polarization fluctuation.

The AD average number defines the number of AD samples averaged to obtain the feedback signal value used for one control loop cycle. Increasing the AD average number can improve the stability if the feedback signal is noisy. For example, setting AD avg. = 2 converts a 50mV, 10KHz noise component in the feedback signal to a 25mV, 5KHz noise component.

Increasing the AD average number also increases the control loop cycle time by the amount specified in the table.

Figure 14 shows the response of the POS-002, using a larger AD average than the default setting, to the same discontinuous change in the input polarization state used in Figure 7. The output polarization fluctuation (labeled C in Figure 7) is much smaller than in Figure 7.

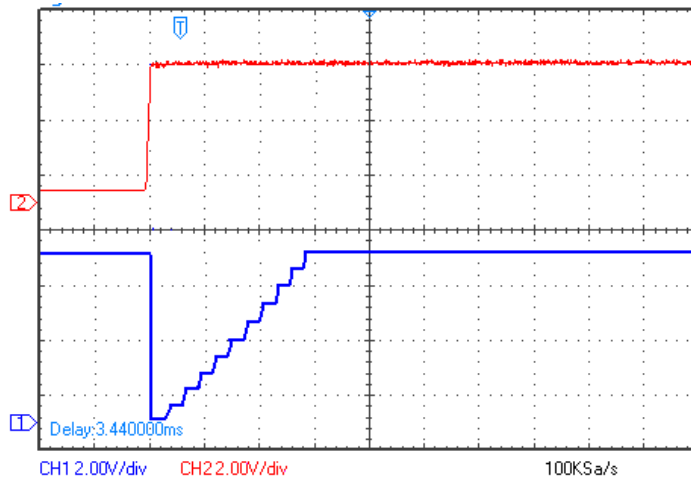

Figure 14 POS-002 response to discontinuous change in input polarization state (AD average larger than default setting)

- **Command: THH xx#**

This command allows the user to control the feedback response threshold.

The response threshold level determines the amount of change in the electrical feedback signal needed to elicit a polarization change response from the POS-002. When the POS-002 is enabled, it performs an SOP search for an SOP that maximizes (or minimizes, as the case may be) the feedback signal. Once this reference level is established, each cycle, the POS-002 reads the feedback signal level and compares it to the reference level. If the current feedback signal value differs from the reference level by more than the threshold setting, the POS-002 will adjust the polarization state. If the difference is less than the threshold setting, the POS-002 will continue to monitor the AD feedback signal, but will not change the polarization state. The external feedback POS-002 uses a 0 ~ 5V analog electrical feedback signal, which is converted to $2^{12} = 4096$ digital steps for the purposes of the control algorithm. For the AD feedback, 1 digital step = $5V/4096 = 1.22mV$. The *THH xx# command sets the response threshold (i.e. the minimum amount of change from the reference level that will result in a polarization state correction from the POS-002) to $xx * 1.22 \text{ mV}$. For example, if for a given laser source, the POS-002 stabilizes the SOP such that the feedback signal reaches a maximum of 4V, then, with the threshold level at the default setting, as long as the feedback signal remains higher than $4V - 0.00122V = 3.99878V$, the POS-002 will not actively change the polarization.

The threshold control command can be used to reduce the effect of noise. If the SOP variation is relatively slow and the feedback signal has a known noise level, the threshold can be set to be larger than the noise so that the POS-002 will react only to perceived polarization changes above the noise level.

However, a large threshold setting can also result in larger output polarization fluctuation because the POS-002 will not react to actual polarization drift within the threshold interval. Figure 15 shows the response of the POS-002, using a relatively large threshold setting, to the same discontinuous change in the input polarization state used in Figure 7. The output polarization fluctuation (labeled C in Figure 7) is larger than in Figure 7.

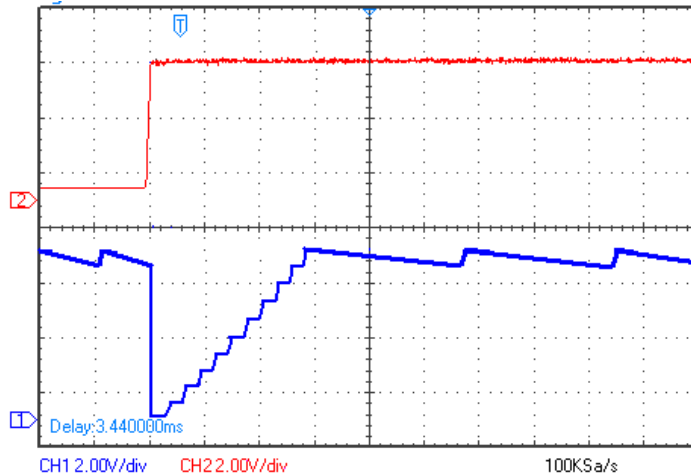

Figure 15 POS-002 response to discontinuous change in input polarization state (response threshold larger than default setting)

For high sensitivity applications with clean feedback signals, the threshold should generally be left at 0 (default value).

4.4.3 RS-232 troubleshooting

If a problem occurs during RS-232 control, please check the following:

1. Pin connections; make sure that the correct pins on the POS-002 are connected to the corresponding pins on the computer RS-232 port.
2. Verify active Comm Port (COM1, COM2, etc.);
3. Verify Comm Port settings: 8 data bits, 1 stop bit, no parity bits;
4. Check baud rate: must be 9600 bps;
5. Check commands: command should begin with “*” and end with “#” or “?”

4.4.4 LabView control program

The command list in Table 2 can be used to write control programs for the Pos-002. General Photonics provides a sample control program that can be used as a base for customization by the user. The program is written in LabView. The source code (vi files) can be opened and edited using LabView 2012 SP1 or above.

For users who do not need to customize the control program or do not have LabView installed on the control computer, General Photonics also provides an executable version of the program for added convenience.

Driver Installation

If the control computer does not have LabView (2012 SP1 or above) installed, then the LabView Run-Time Engine and VISA Run-Time Engine are required to run the executable version of the control program. The installation files for both run-time engines are in the “LabView Run-Time” folder on the software cd, and can also be downloaded from the National Instruments website (ni.com).

Note: LabView Run-Time Engines are version specific and are not backward compatible, so make sure that the correct versions are installed on the control computer. The versions required for the SLD-101 control program are:

LabVIEW Run-Time Engine 2012 SP1 - (32-bit):

Operating system: Windows 8; Windows 7; Windows Vista; Windows XP (SP3) 32-bit; Windows Server 2008 R2 64-bit; Windows Server 2003 R2 32-bit

NI-VISA Run-Time Engine 5.3:

Operating system: Real-Time OS; Windows 7 64-bit; Windows 7 32-bit; Windows Vista 64-bit; Windows Vista 32-bit; Windows XP; Windows XP Embedded; Windows Server 2008 R2 64-bit; Windows Server 2003 R2 32-bit

Note: Always close the control program (and LabView as well if using the VI version of the control program) before turning off the instrument.

The screen layouts for the control programs “POS_REMOTE.vi” (source code) and “POS_REMOTE.exe” (executable) are shown below.

The control port selection menu is located at the top right of the interface screen, under the product identification box. It displays the selected port for the RS-232 connection. If the selected port and the actual connection do not match, the program will not function correctly. Set the correct port number here. The port number can be determined from the Device Manager or from National Instruments’ Measurement & Automation program. Note that the port number cannot be set while the program is executing (trying to communicate with the instrument). Stop the program first (stop sign or Ctrl + .), then choose the correct port, if necessary. Note that ASRL1:INSTR is the same as COM1. Use the white arrow or Ctrl+R to restart the program.

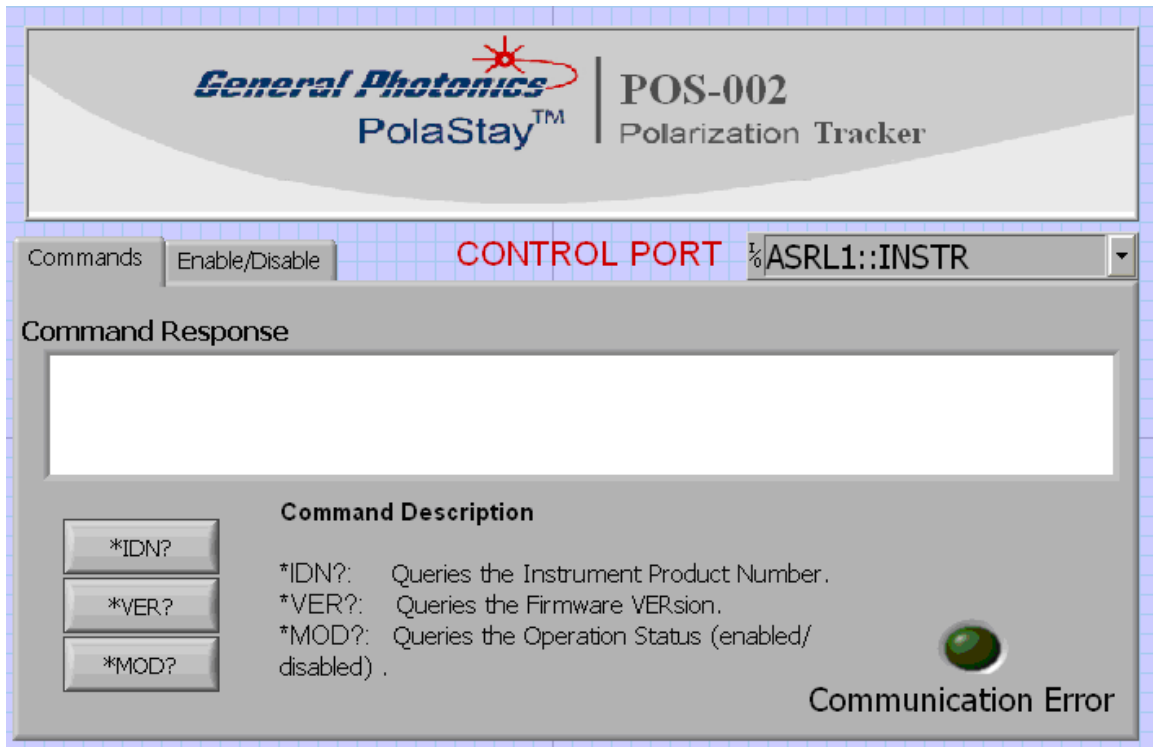

This is the POS-002 version and status identification interface.
The descriptions of the items on the screen are as follows:

Command buttons (bottom left of screen): Clicking a command button from this screen sends the corresponding command to the POS-002.

Command Response box: Displays the POS-002's response to the command. See Table 2 and Table 3 for more detail on responses to version/status query commands.

Communication Error: Indicator light turns on if a communication interruption occurs while the POS-002 is attempting to communicate with the computer.

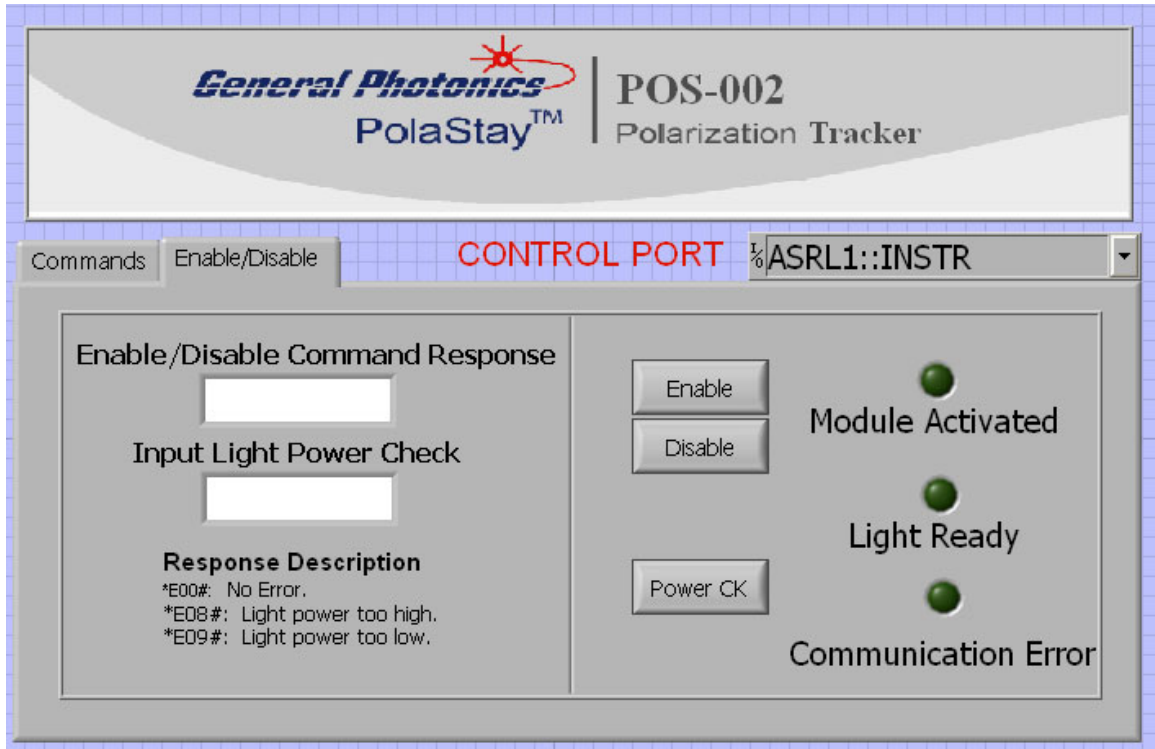

This is the POS-002 operation interface.
Items on the screen are as follows:

Enable/Disable buttons: Click to enable or disable the polarization tracker.

Module Activated: Indicator light turns on when the module is enabled, off when the module is disabled.

Enable/Disable Command Response box: Displays POS-002 response to the enable or disable command. Response should be “*E00#” if the command was successfully received.

Power CK button: Checks input light level on an internal feedback POS-002.

Light Ready: Indicator light turns on after “Power CK” is clicked if the light level is within range.

Input Light Power Check box: Displays POS-002 response to the “power check” command. Response is “*E00#” if light level is within range, “*E08#” for power high, and “*E09#” for power low.

Communication Error: Indicator light turns on if communication is interrupted while the POS-002 is trying to communicate with the computer.

Section 5. Application Examples

5.1 PMD compensation

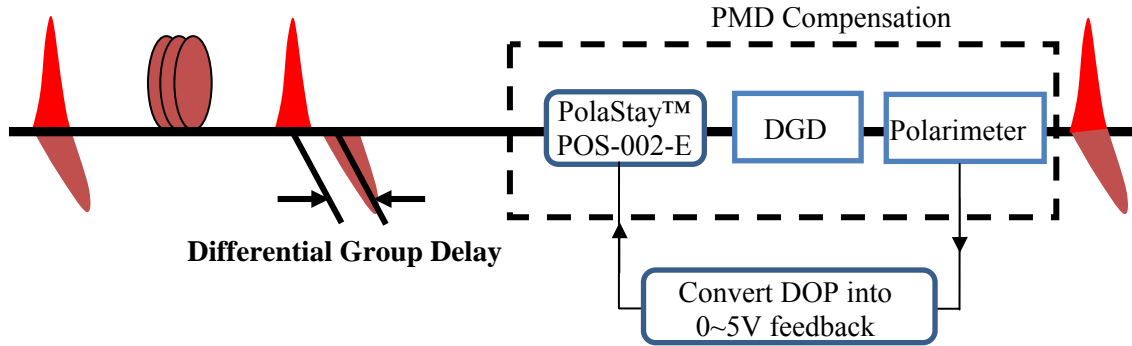

Scheme 1: Use a polarimeter to obtain a feedback signal. In this scheme, a polarimeter is used to detect the degree of polarization (DOP) of the signal to indicate the PMD effect on the signal. The DOP will be maximized when the PMD is properly compensated. The user constructs a simple circuit to convert DOP into an analog signal between 0.5 and 4.5V and feeds this signal back to the POS-002-E. The polarization tracker then automatically maximizes DOP to achieve PMD compensation.

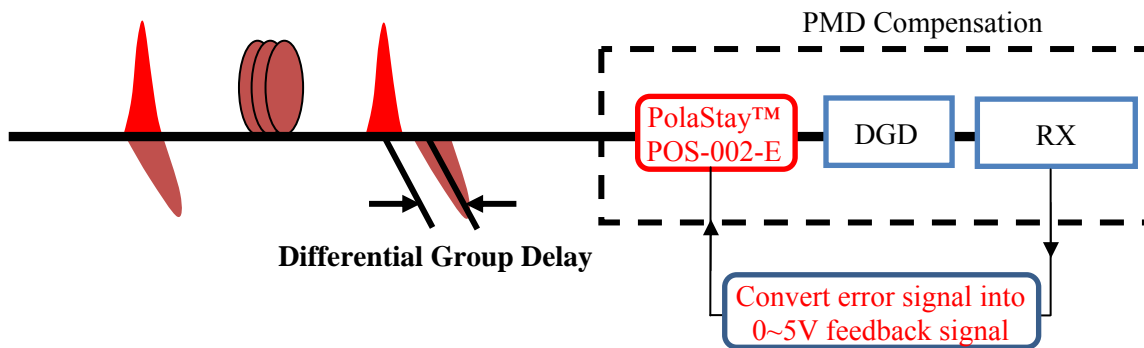

Scheme 2: Use the receiver to obtain the feedback signal. In this scheme, the error signal indicating the PMD effect can be a clock signal from the receiver's photodetector or a BER detected before FEC inside the receiver. The user converts the error signal into an analog signal between 0.5 and 4.6V volts and feeds it back to the POS-002-E. The polarization tracker then either maximizes or minimizes the error signal to achieve PMD compensation.

5.2 Polarization Demultiplexing

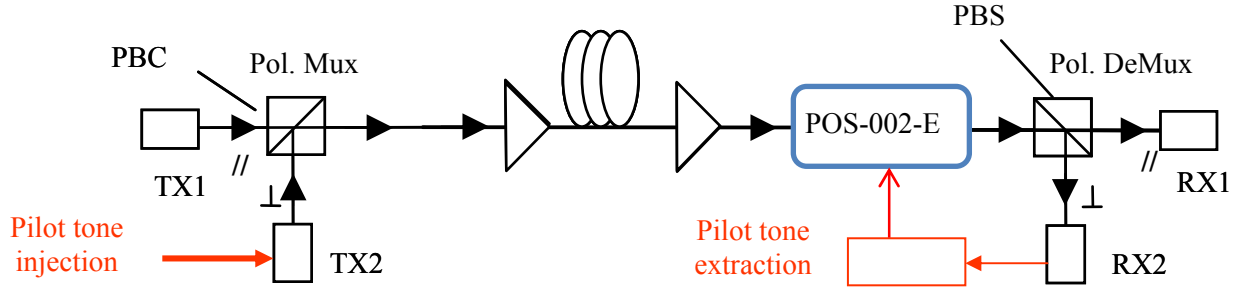

Scheme 1: Pilot tone detection. A low frequency pilot tone around 100 kHz is injected at one of the transmitters. At the receiving end, a pilot tone extraction circuit can be used to detect the strength of the pilot tone and convert it into a 0.5 to 4.6V feedback signal for the POS-002-E. The detected pilot tone will be maximized when the two polarization channels are properly separated. The polarization tracker then automatically maximizes the feedback signal to separate the two polarization channels.

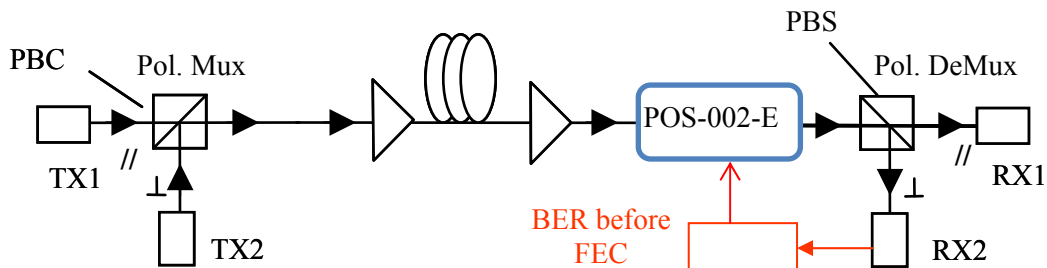

Scheme 2: BER detection. The bit-error rate (BER) before the forward error correction (FEC) in the receiver is detected as the error signal for polarization demultiplexing. The BER will be minimized when the two polarization channels are properly separated. A simple circuit can be used to convert the BER into a 0.5 to 4.5V feedback signal for the POS-002-E: the bigger the voltage, the smaller the BER. The polarization tracker then automatically maximizes the feedback signal to effectively separate the two polarization channels.

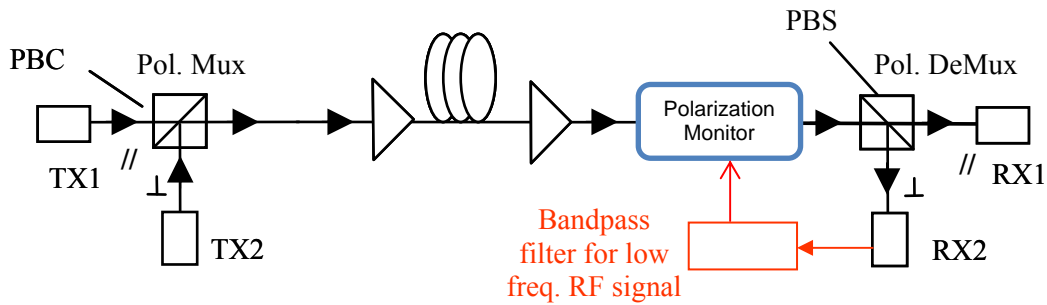

Scheme 3: Low frequency RF detection. The low frequency correlation noise between two polarization channels is an indication of the channel crosstalk. The noise will be minimized when the two polarization channels are properly separated. A low frequency photodetector followed by a bandpass filter can be used to detect the noise level. A simple circuit can be used to convert the noise level into a 0.5 to 4.6V feedback signal for the POS-002-E: the bigger the noise, the smaller the feedback signal. The polarization tracker then automatically maximizes the feedback signal to effectively separate the two polarization channels.

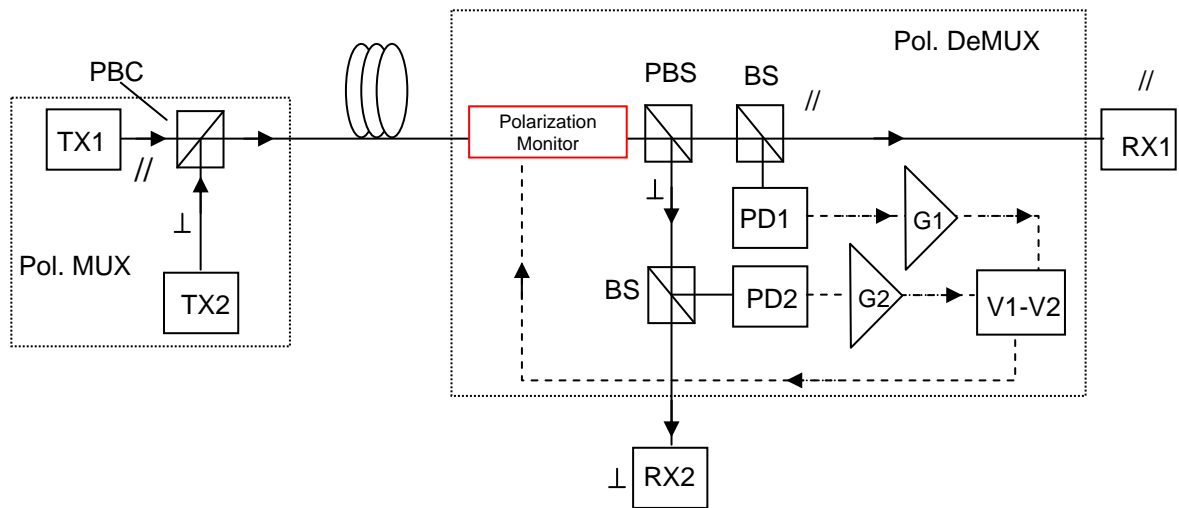

Scheme 4: Power imbalance detection. The two polarization channels are set at different power levels and the detected power difference is an indication of polarization channel separation. A simple circuit can be used to convert the noise channel power difference into a 0.5 to 4.6V feedback signal for the POS-002-E. The polarization tracker then automatically maximizes the feedback signal to effectively separate the two polarization channels.

5.3 Coherence detection

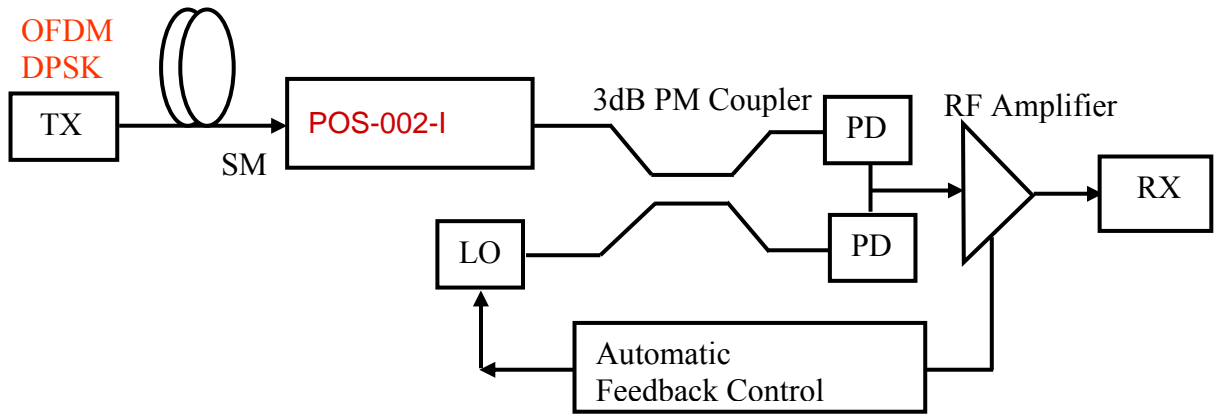

In a coherent detection system, the states of polarization of the signal and local oscillator must be the same in order to maximize signal to noise ratio. A POS-002-I can be used to stabilize the SOP of the signal after it propagates through the transmission fiber. The SOP of the output of the polarization tracker is linear and aligned with the slow axis of the PM fiber pigtail and will beat with the local oscillator.

5.4 Polarization tracking for sensor system

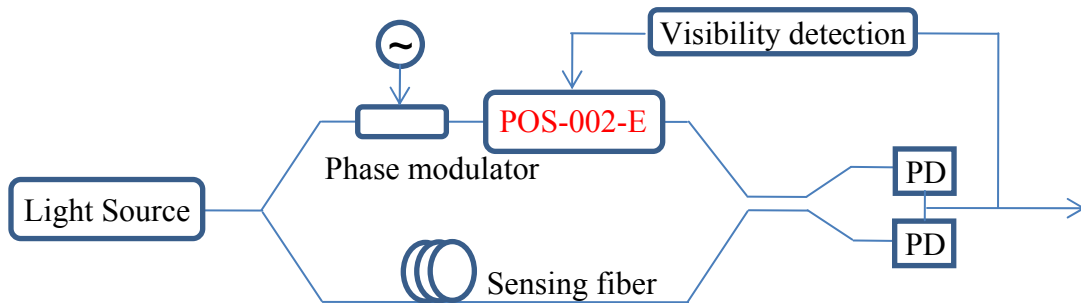

In an interferometric sensor system, the detection sensitivity is directly related to the SOPs of the two interfering signals. A POS-002-E can be used to obtain the maximum detection sensitivity. In this application, the visibility of the sensor can be monitored with a phase modulator and can be converted into an analog signal between 0.5 and 4.6V to be fed back to the POS-002-E. The polarization tracker then automatically maximizes the visibility for stable, optimized detection sensitivity.

Section 6. Technical Support

General Photonics is committed to high quality standards and customer satisfaction. For any questions regarding the quality and the use of the POS-002, or future suggestions, please contact General Photonics Corporation at (909)-590-5473 (telephone) or (909)-902-5536 (fax), or by e-mail at info@generalphotonics.com. General Photonics will respond to all customer questions within 24 hours during regular business hours. You can also write to:

General Photonics
5228 Edison Avenue
Chino, California 91710
USA